

Center for
Quantum Networks
NSF Engineering Research Center

Optical transmission systems for quantum networks

Instructor: Dan Kilper
– Trinity College Dublin

Co Instructor: Shelbi Jenkins
– University of Arizona

This work is supported primarily by the Engineering Research Centers Program of the National Science Foundation. Any opinions, findings and conclusions or recommendations expressed in this material are those of the author(s) and do not necessarily reflect those of the National Science Foundation.

CQN Winter School on Quantum Networks in partnership with CONNECT

Funded by National Science Foundation Grant #1941583

CONNECT
SFI Research Centre for
Future Networks



Course Outline

- Introductions and motivations
- Classical optical transmission systems
- Communication system and network engineering
- Quantum systems and coexistence
- Field trials and test bed experiments

CONNECT: SFI Center of Excellence in Future Networks & Communication



- Optical, Wireless, & Data Communications in Smart Cities, IoT, ITS, Cloud
- Transformative Research on Security, Dependability, Sustainability, AI/Data Driven Intelligence, Customizability & Scalability
- Quantum Internet Technologies
- 19 PIs, 50 Funded Investigators, over 250 Researchers in Total
- €90M over 6 years, SFI+Industry+European funding



Convergent Quantum REsearch Alliance in Telecommunications: CoQREATE



SFI+DFE+NSF US-Ireland Centre to Centre Program

CQN: U. Arizona, MIT, Harvard, Yale, N. Arizona, U. Mass., Howard, U. Oregon, BYU, U. Chicago; QTeQ: Queens U. Belfast; CONNECT: TCD, UCD, UCC, Tyndall, DCU, Maynooth, U. Limerick, SETU, MTU, TUD

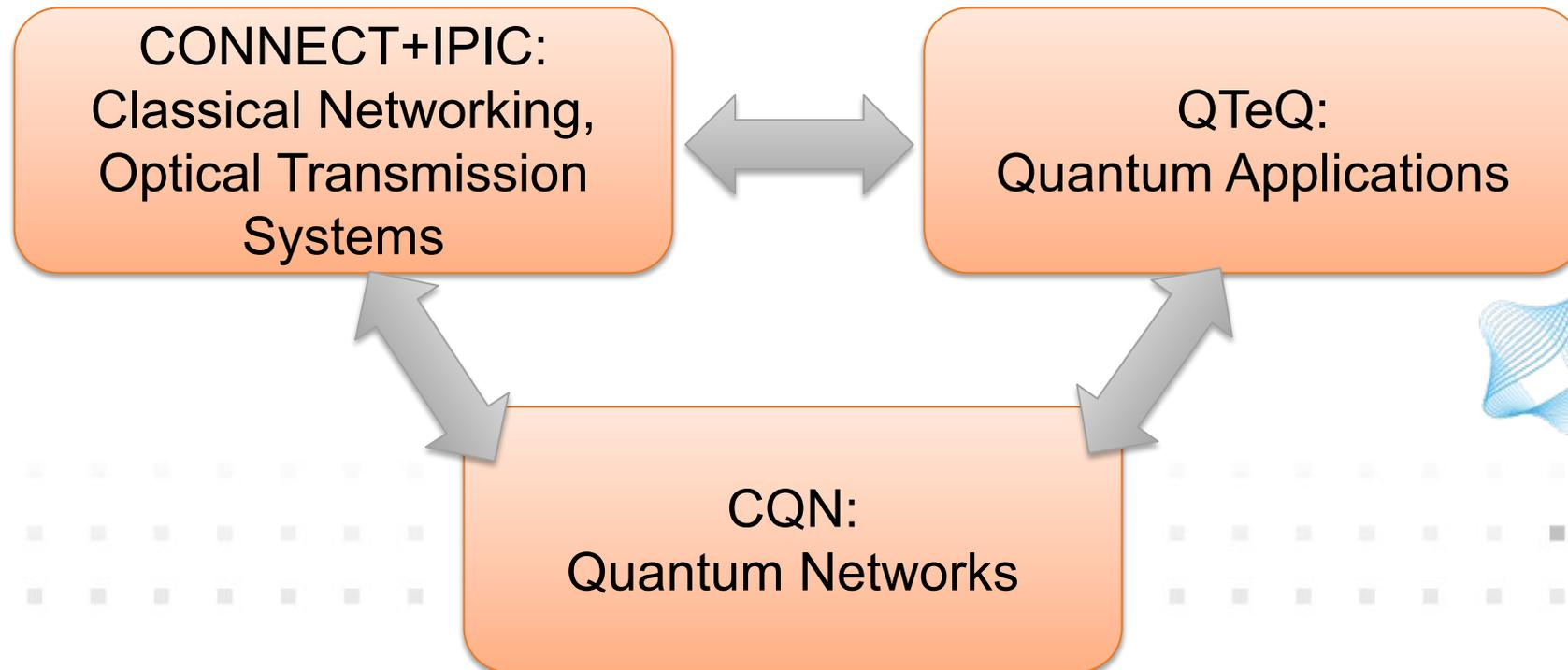

CoQREATE
Convergent Quantum Research
Alliance in Telecommunications

Goals & Objectives

- Foster deep collaboration between quantum and classical networking communities
- Bring centre-scale research to critical interdisciplinary challenges for terrestrial & satcom-assisted quantum networks
 - Coexistence and transmission technologies and design
 - Network control and architectures
 - Device packaging and interfacing
 - AI/ML network control and design
 - Satellite communication assisted quantum networks



Optical Communication Systems

Long Haul System

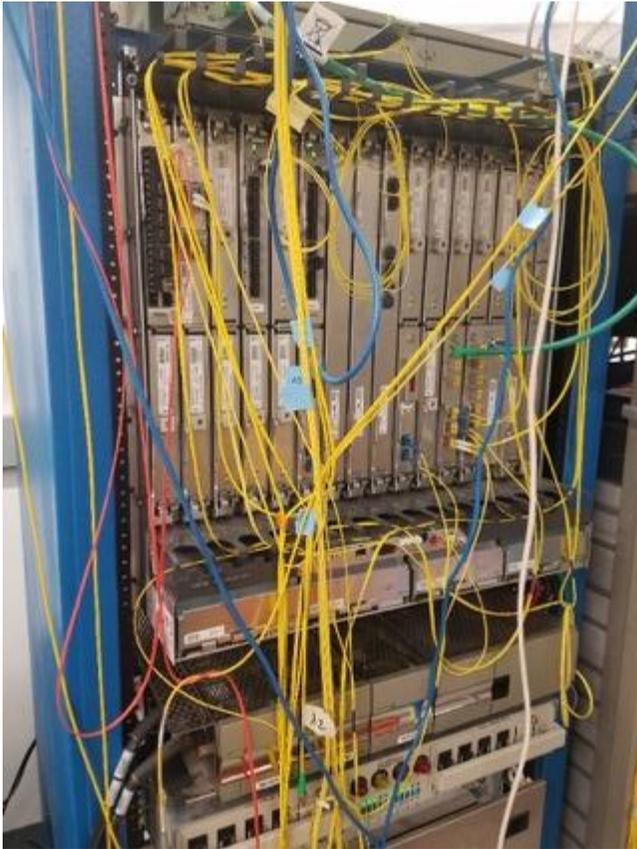

Metro System



Optical Switch



PON Access System

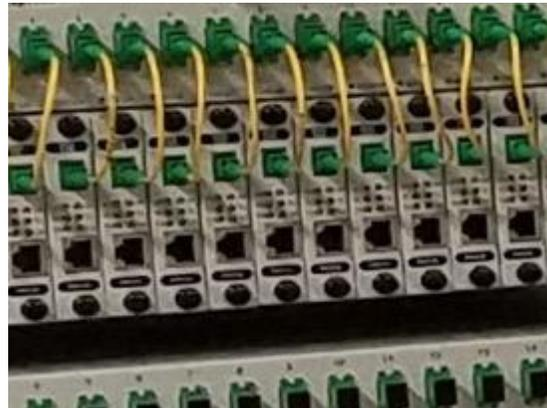

Data Center Network



Satellite communication system

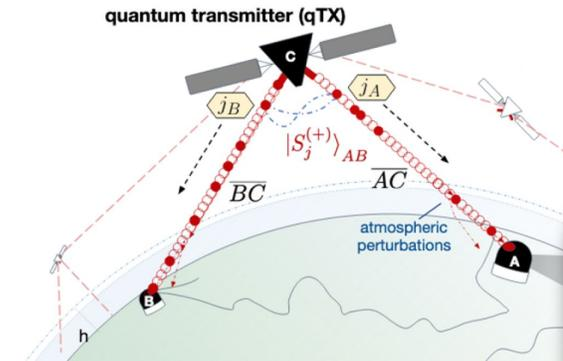

Submarine Fiber Cable Ship



The network today

- No point-to-point trans-continental links
- Carriers continue to build out large mesh network
- Connecting in regional and metro networks



Why quantum networks?

- Secure communications and identification
- distributed quantum computing
- clock synchronization
- quantum sensor networks
- extended baseline for telescopes

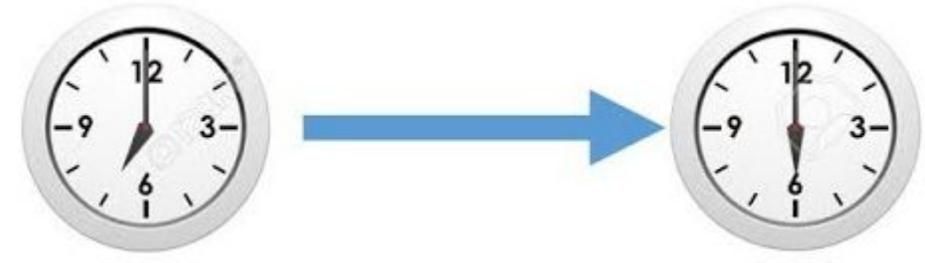

Quantum cryptography model: The case of Alice, Bob and Eve

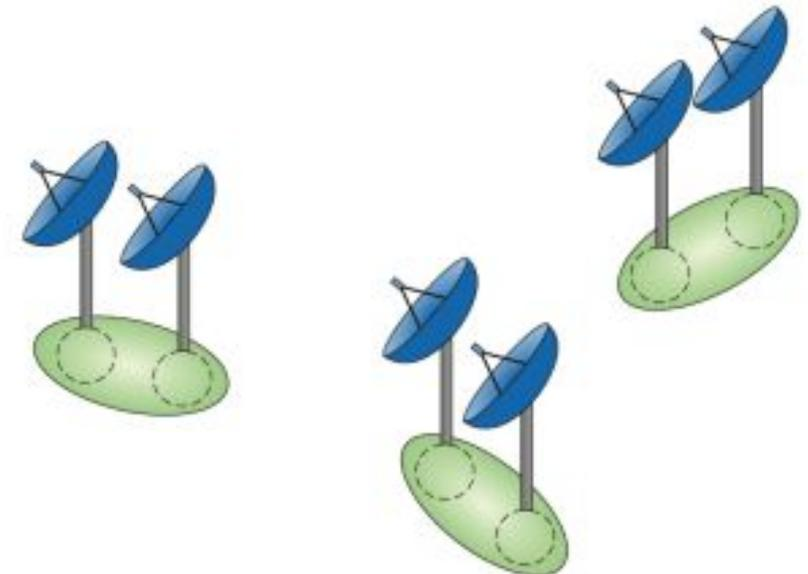
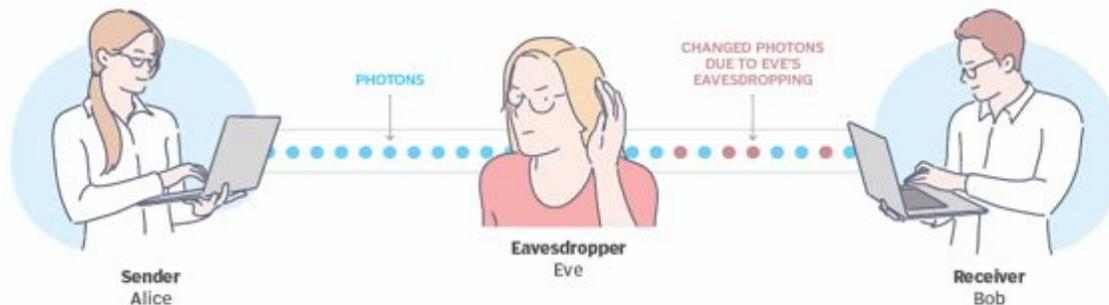

Classical optical transmission systems

Classical network components

Long-haul and Metro networks

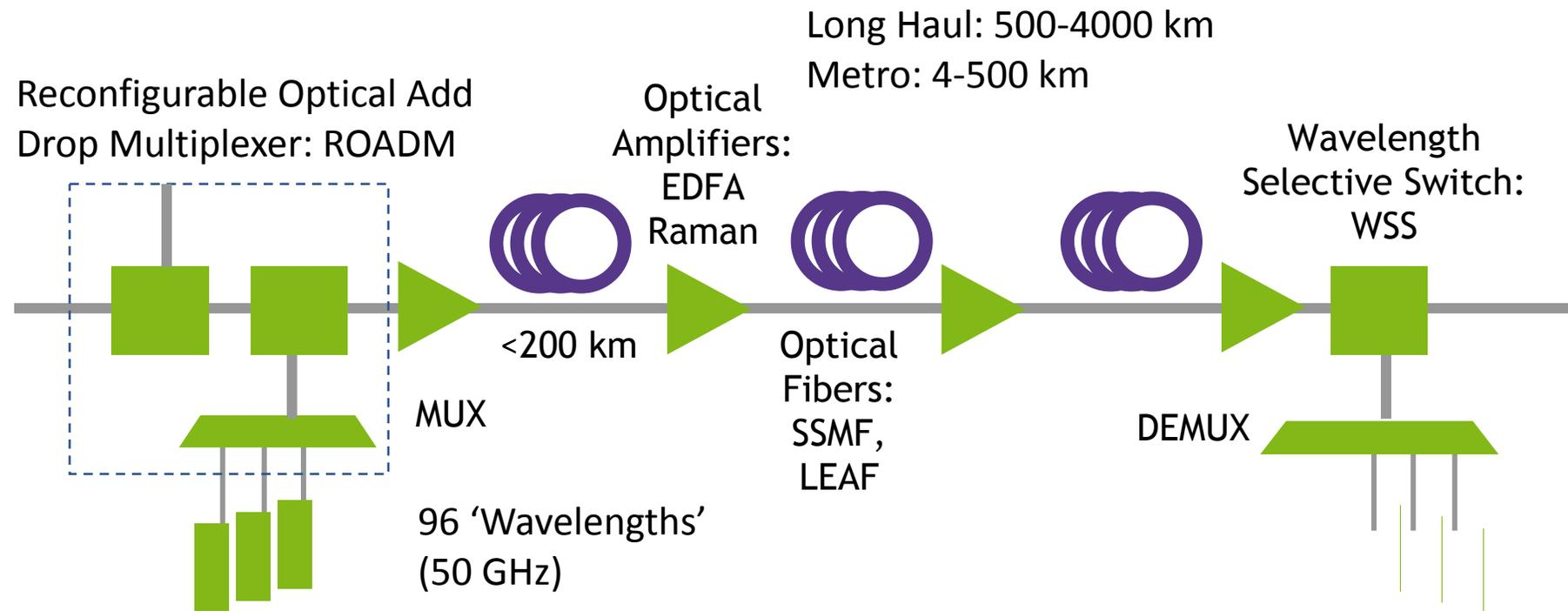

Optical fiber characteristics

Optical fibers

- Single mode
- Multimode
- Step index
- Graded index
- Material selection
 - Glass
 - Plastic
 - Doped fibers

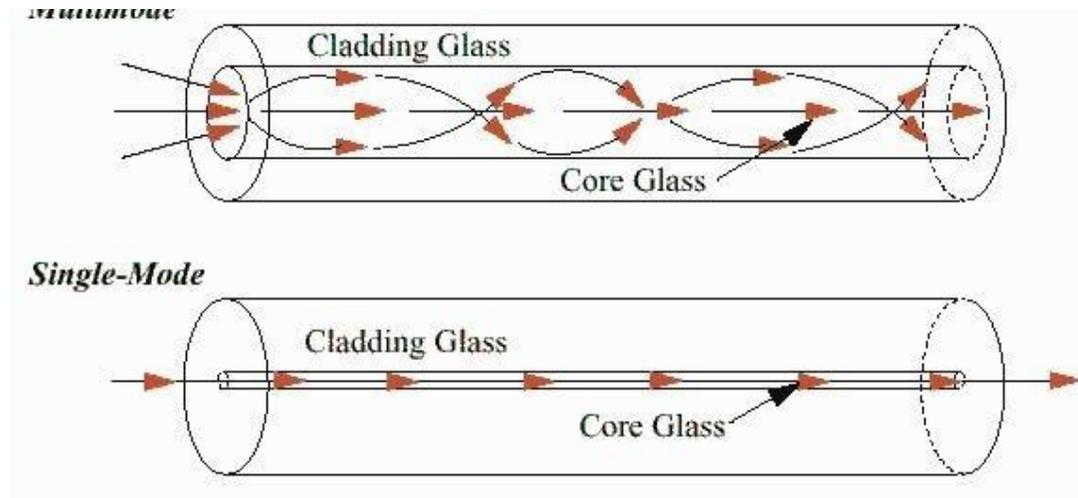
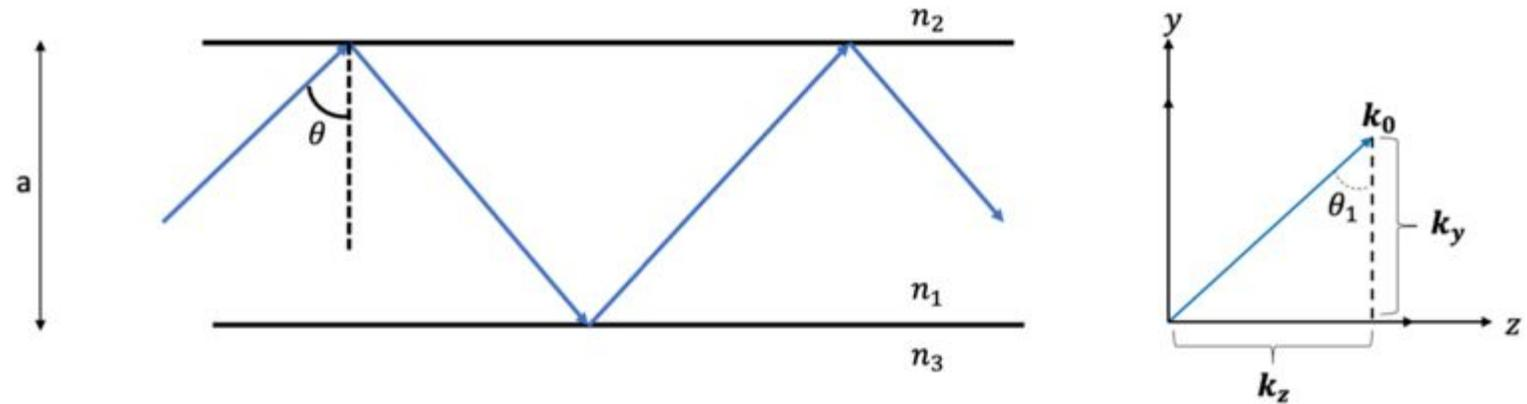



Optical fiber characteristics

Loss mechanisms in fiber

- Absorption
- Scattering
 - Rayleigh scattering
 - Mie scattering
- Dispersion
 - Spatial (modal)
 - Chromatic
 - Polarization
- Bending loss

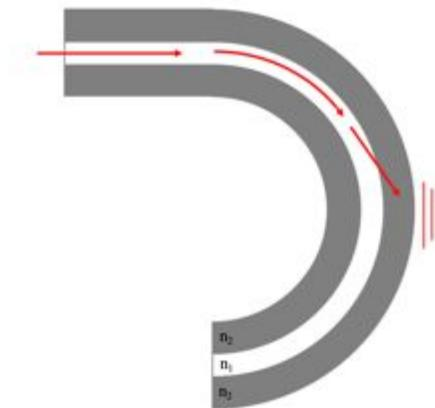
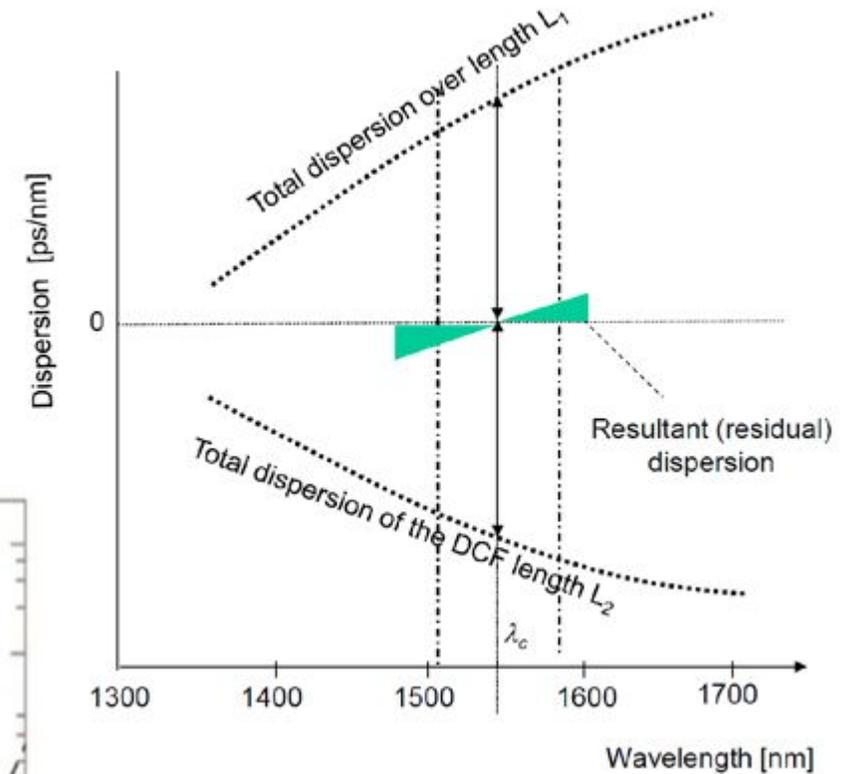
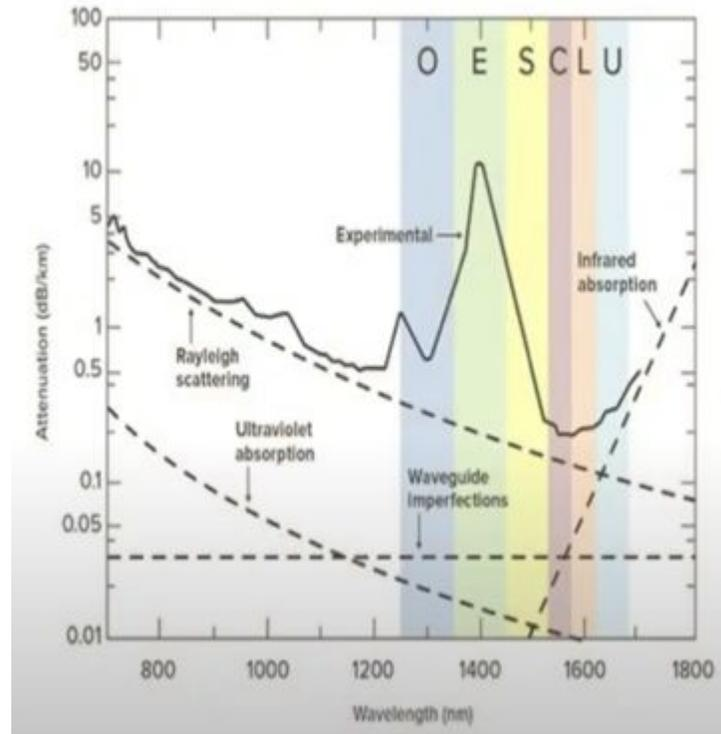
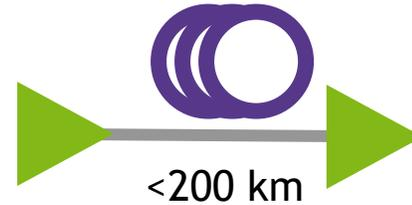

Managing Fiber Loss for Quantum Signals

Practical considerations, standard fiber types

- Loss coefficient varies slightly with wavelength and along the fiber length
 - No two spools are the same
 - Deployed fibers are spliced together every few miles—results in slightly higher loss per distance
 - Metro fibers can be very high loss: 0.3-0.4 dB/km (almost double!)
- Patch panels will kill you: some buildings have multiple patch panels with 0.5-1 dB/panel

Novel fiber types

- Bend insensitive fibers: important in buildings where bends can accumulate
- Avoid polarization maintaining fibers outside the lab due to noise from imperfect connectors
- Hollow core fibers promise lower loss!

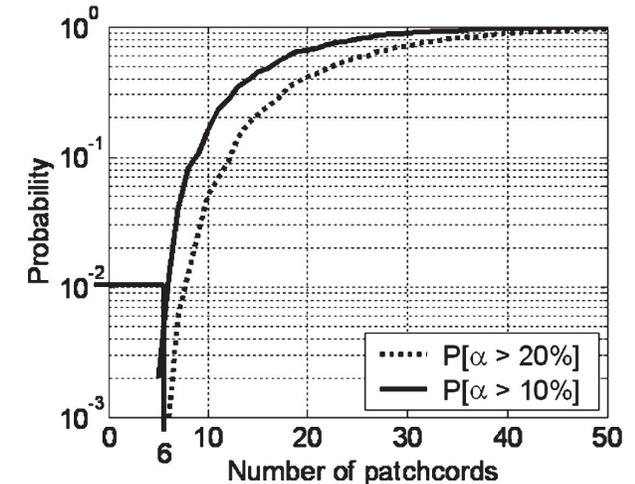

D. Penninckx, N. Beck, J. -F. Gleyze and L. Videau, "Signal Propagation Over Polarization-Maintaining Fibers: Problem and Solutions," in *Journal of Lightwave Technology*, vol. 24, no. 11, pp. 4197-4207, Nov. 2006

Hollow Core Fibers

- Decreased loss with hollow core fibers
 - 0.18 dB/km at 1550 nm
 - 0.22 dB/KM at 1310 nm
 - Potential for order of magnitude lower loss than common fibers today
- Lower nonlinear penalties
- Increased bend loss - limits applications in metro network systems
- Cannot create EDFA or Raman amplifiers

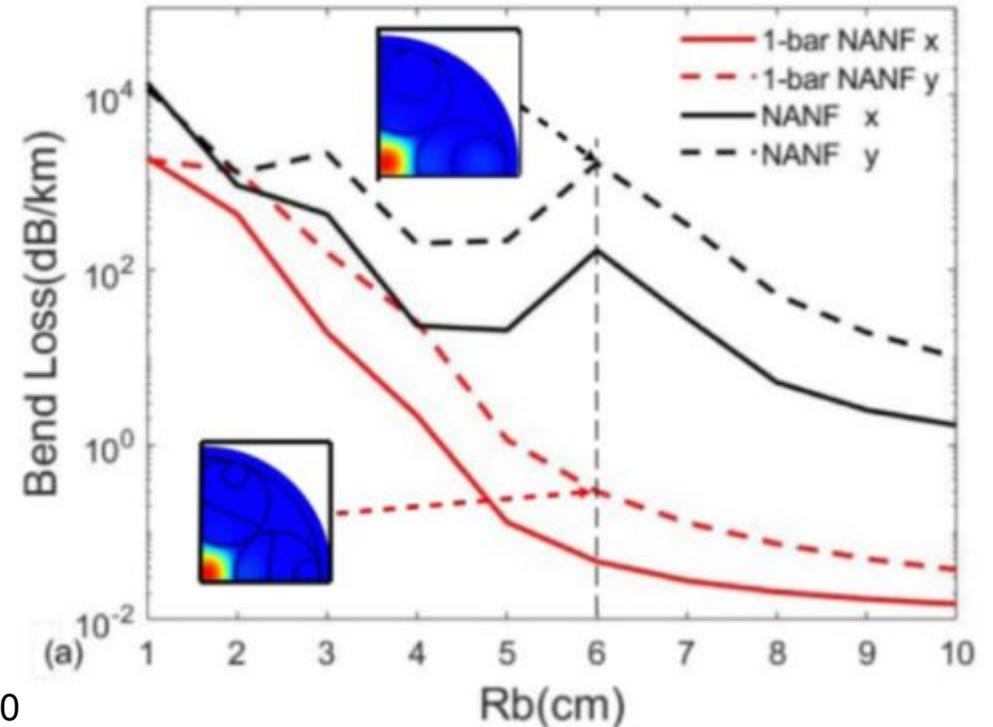
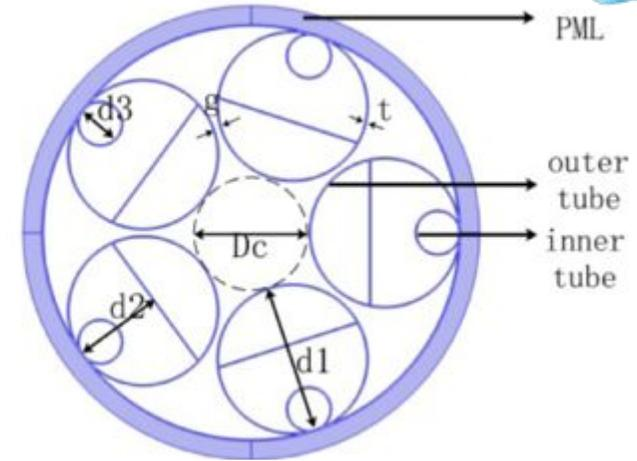

Dispersion and propagation

Jitters in optical networks

- Nonlinear interference signals
- Group delay variation

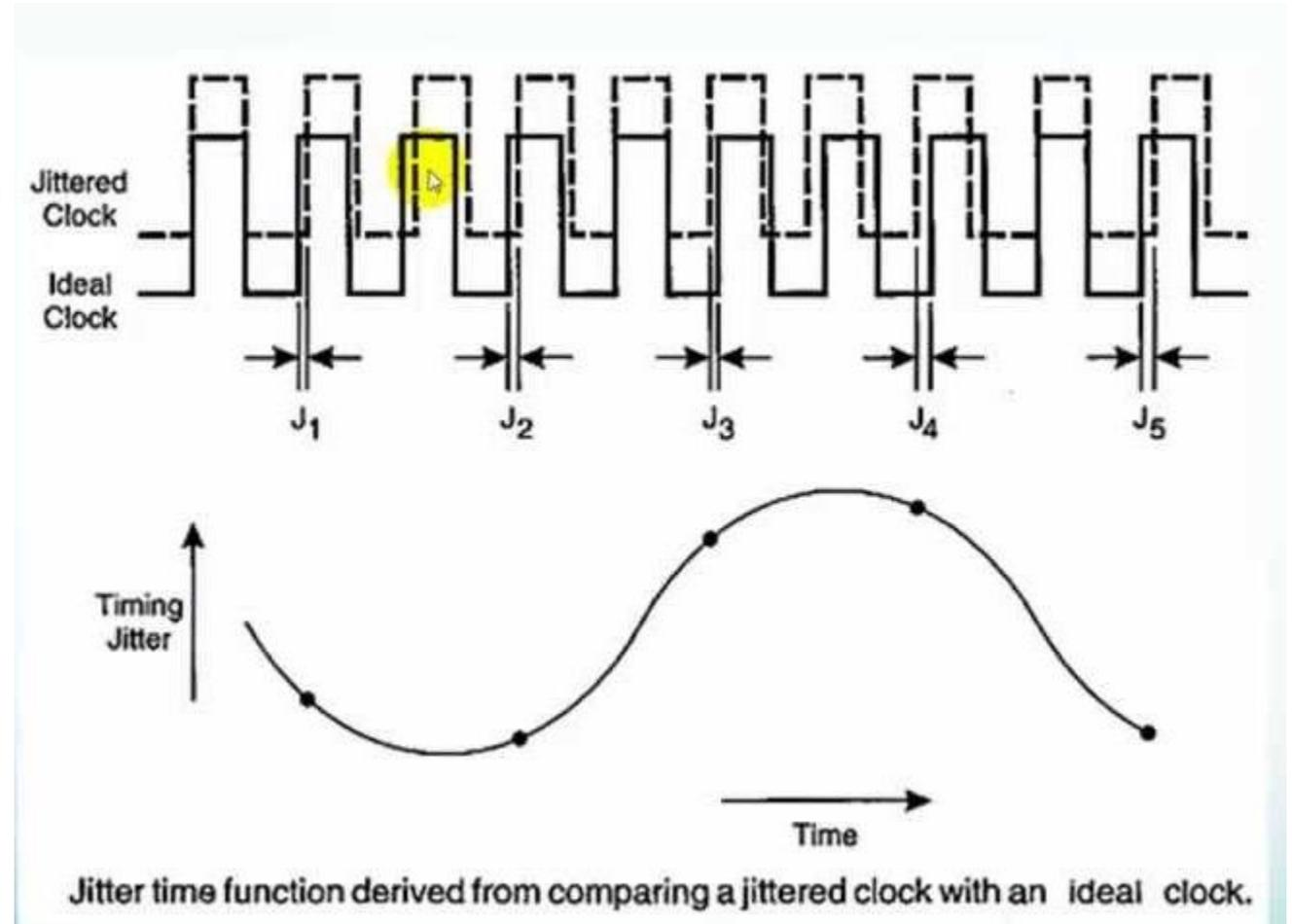
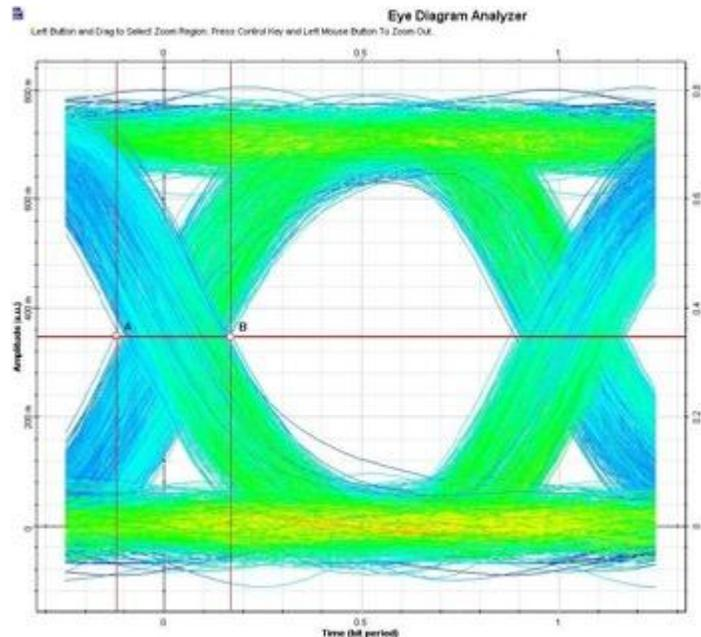



Optical transceivers

Modulation formats

- On/Off keying
- Phase shift keying
- QAM Keying

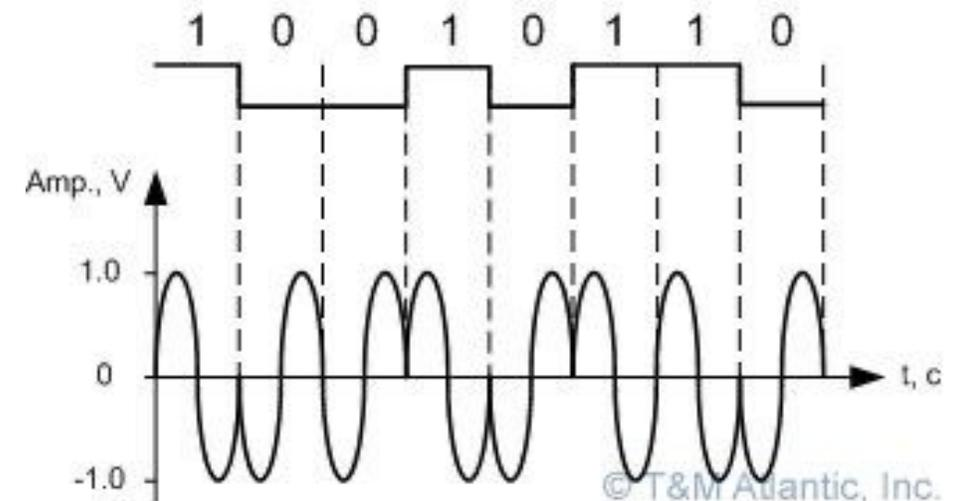
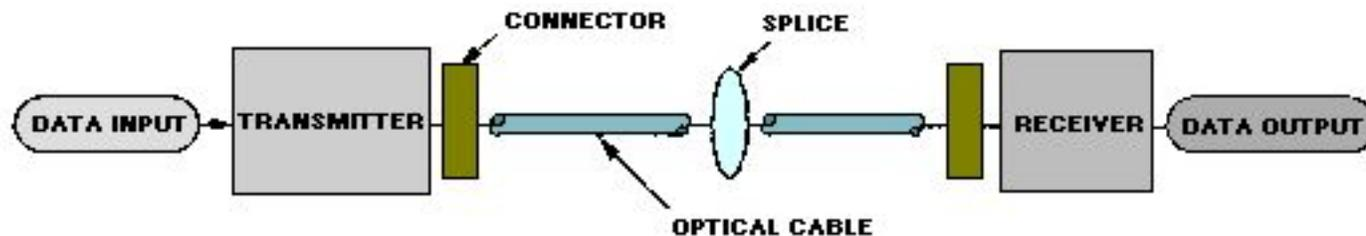
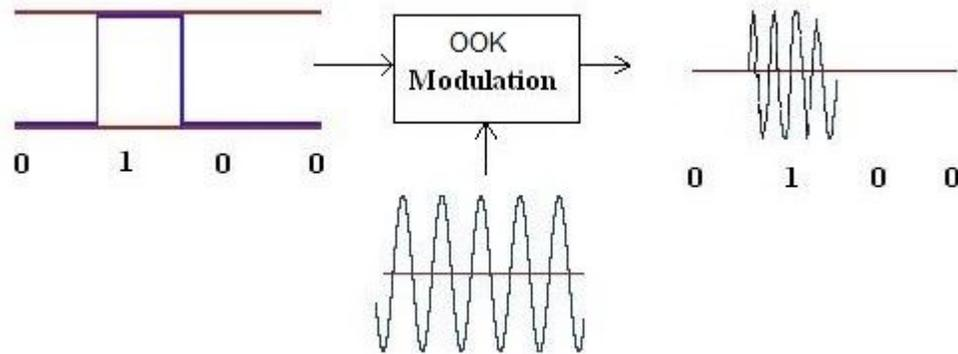
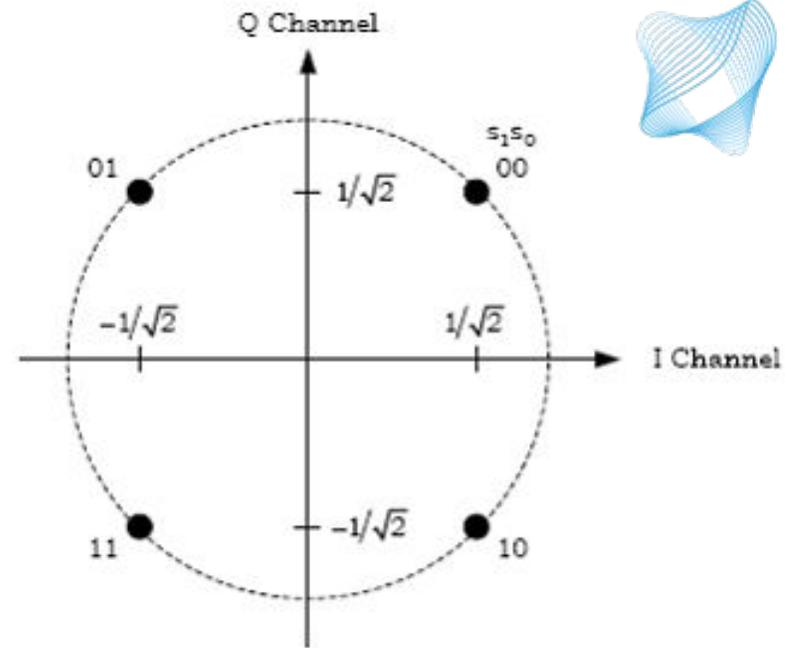

Phase shift keying (PSK)

Optical transceivers

Forward error correction

- Low density parity check (LDPC) in optical systems

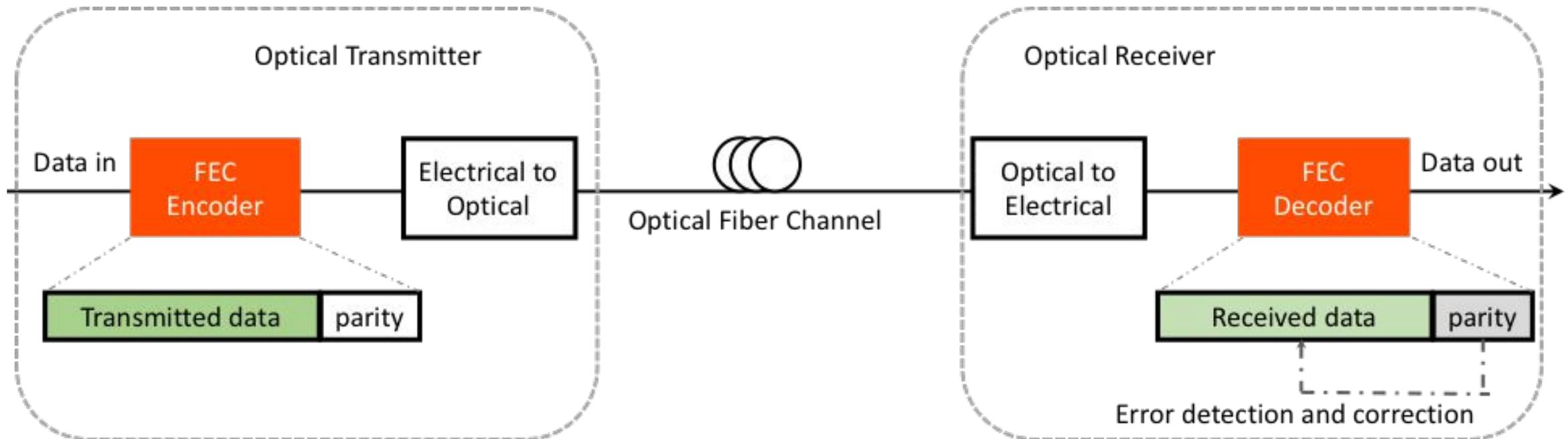

Optical amplifiers

Applications in optical networks

EDFA

Semiconductor amplifiers

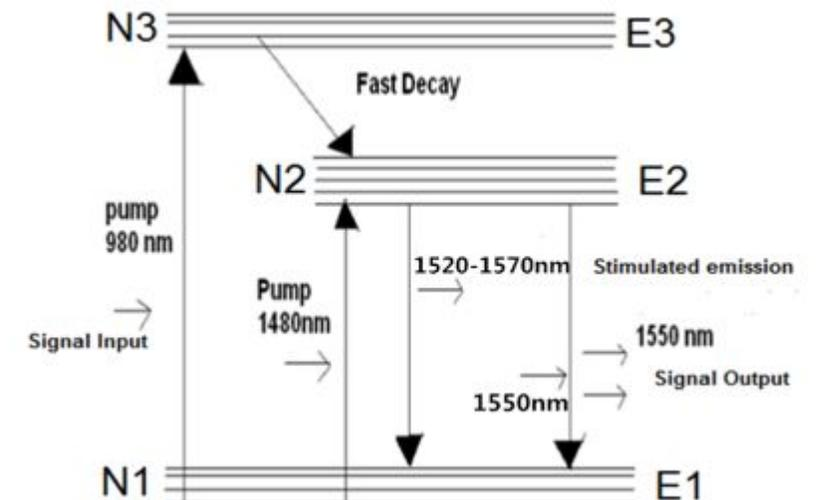
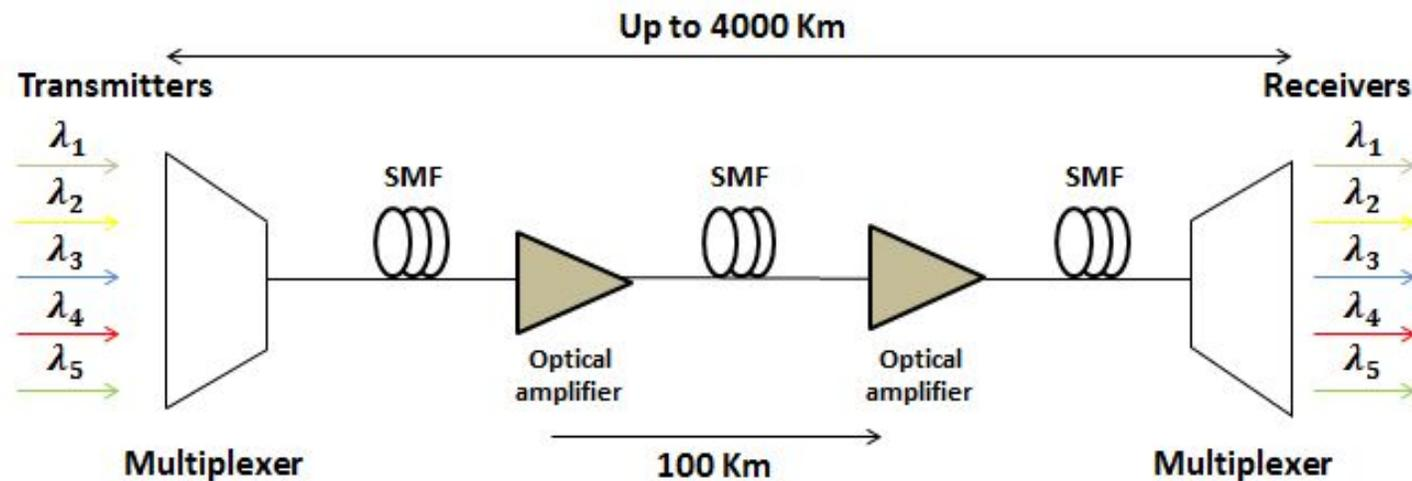
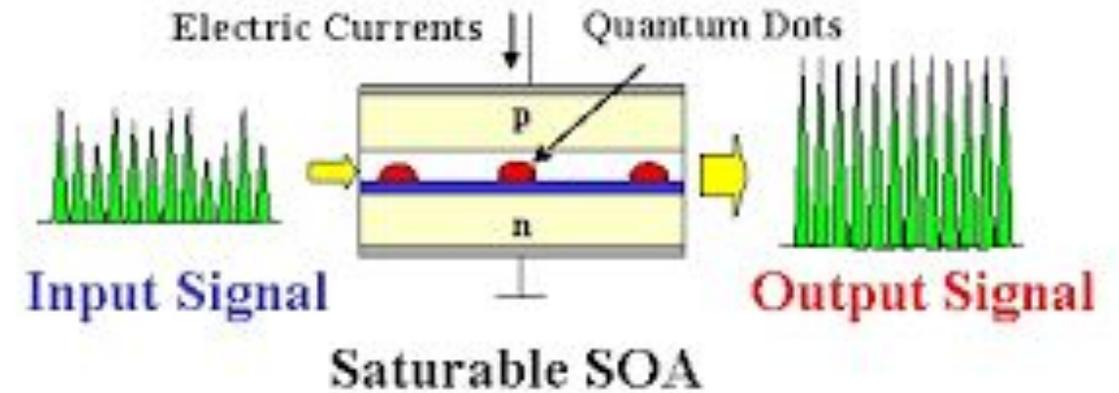

Raman scattering

Spontaneous raman scattering
Stimulated raman scattering for
amplification
Distributed versus discrete
raman amplifications

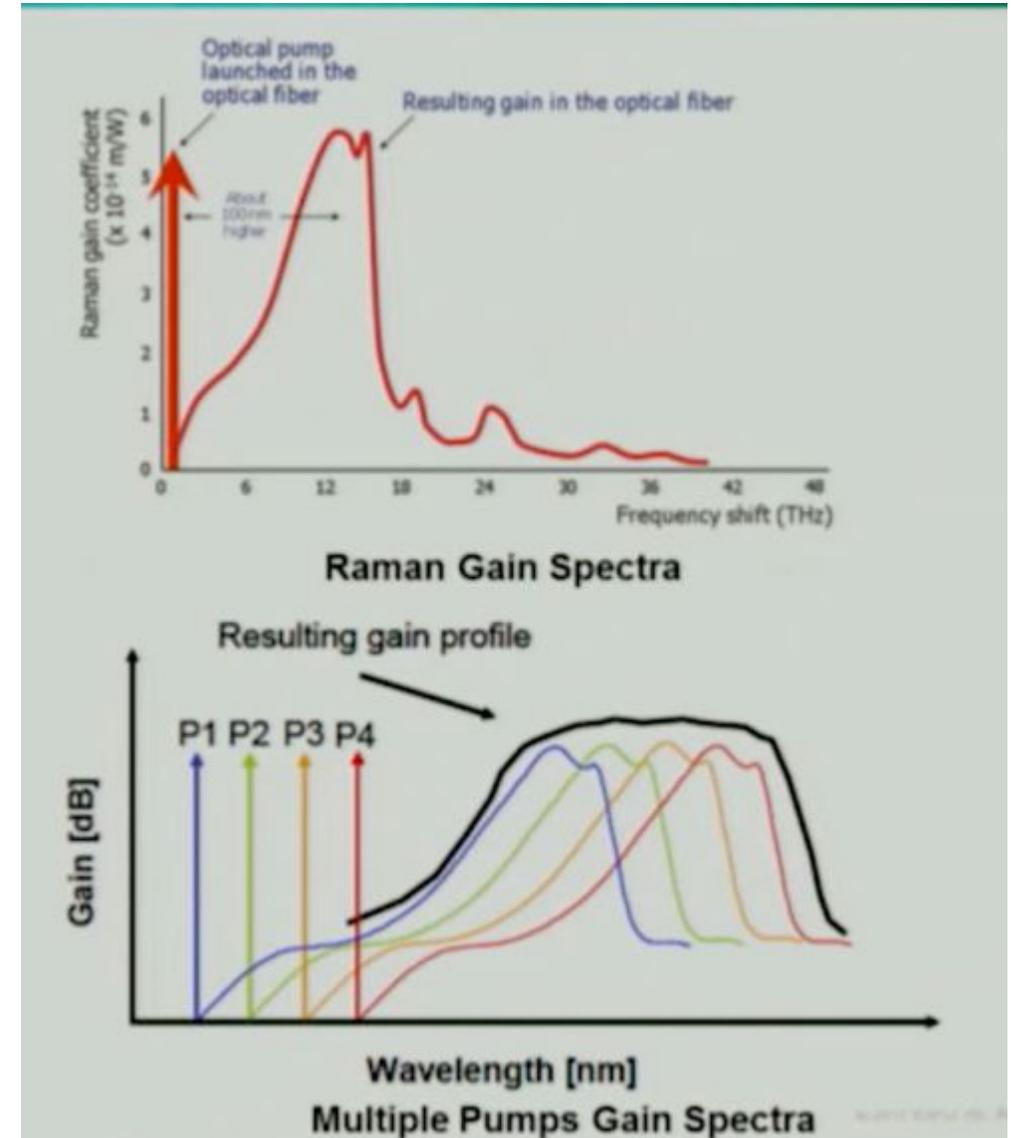
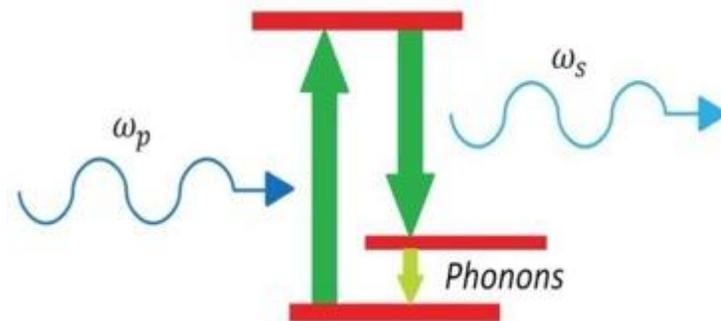
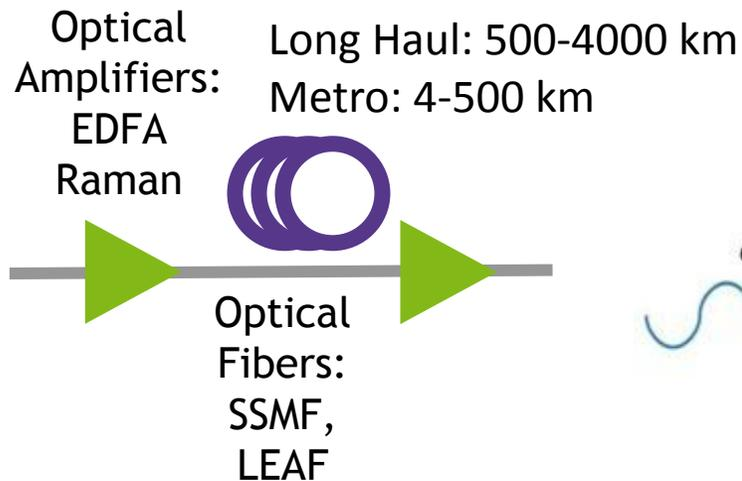

Spectral broadening at zero dispersion:

Nonlinear optical effects

- Optical Kerr effect
 - Self Phase modulation
 - Cross phase modulation
- Implications in optical networks
 - Cross talk

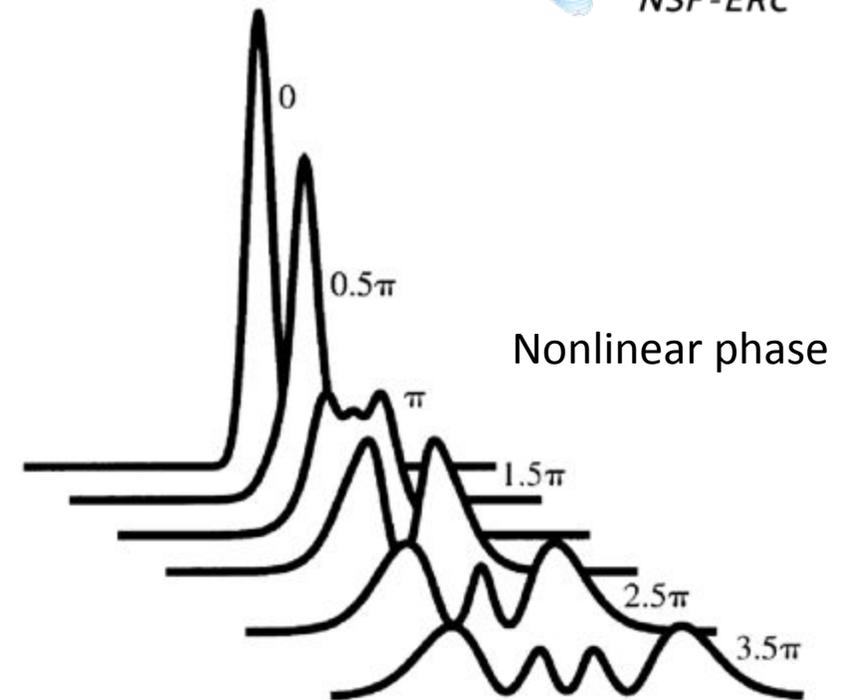
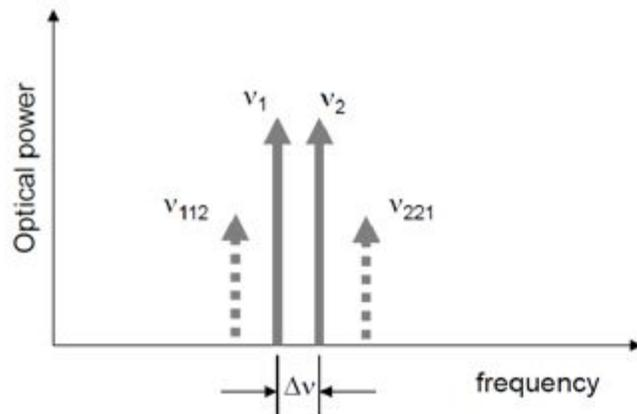
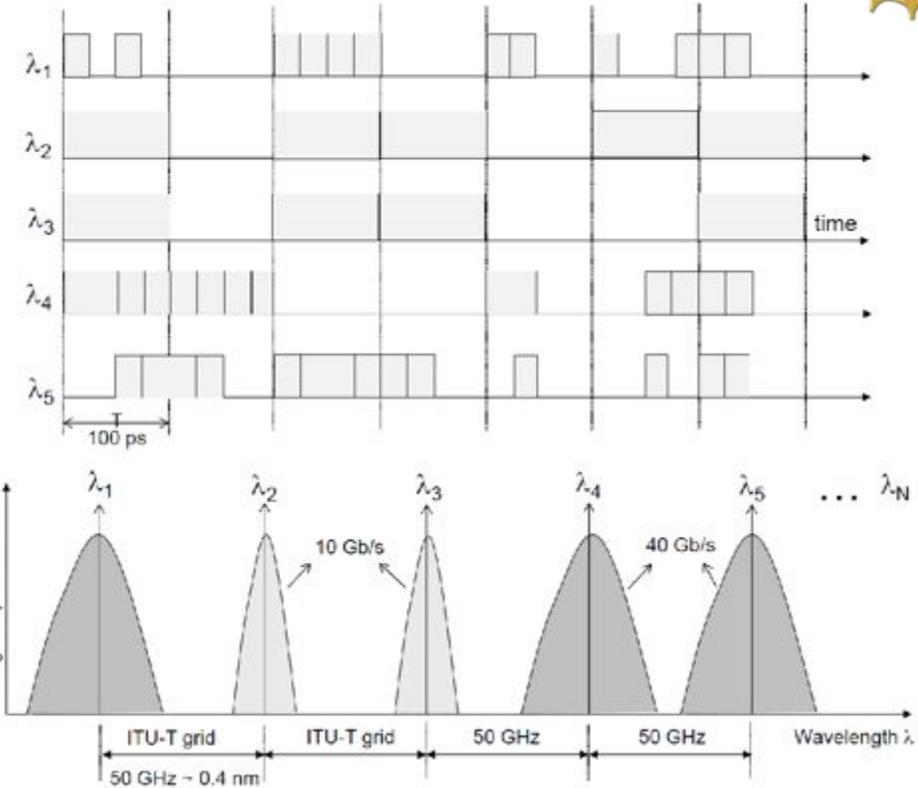

Table 3.1
Typical values of optical fiber nonlinear parameters

<i>Fiber type</i>	<i>Effective area A_{eff}</i> [μm^2]	<i>Nonlinear coefficient γ</i> [$\text{W}^{-1}\text{km}^{-1}$] at 1,550 nm
SMF-28	80	1.12–1.72
AllWave	80	1.12–1.72
LEAF	72	1.23–1.92
Vascade	101	0.9–1.36
TrueWave-RS	50	1.78–2.75
Teralight	65	1.37–2.11

Nonlinear optical effects

- Wavelength division multiplexing (WDM)
- Four wave mixing



(a) Degenerate case

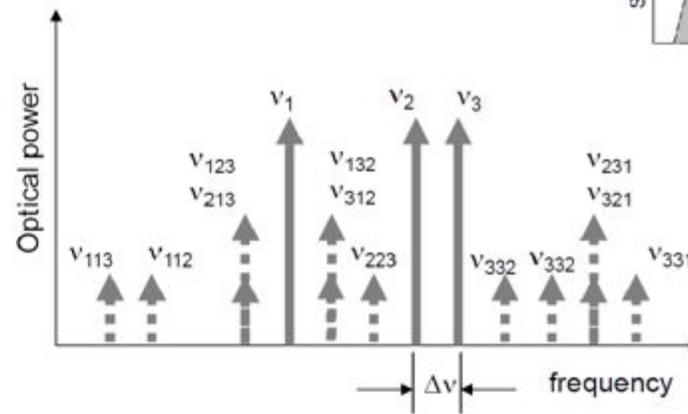

(b) Nondegenerate case



ROADM: Reconfigurable Optical Add Drop Multiplexer Node

Reconfigurable Optical Add Drop Multiplexer: ROADM

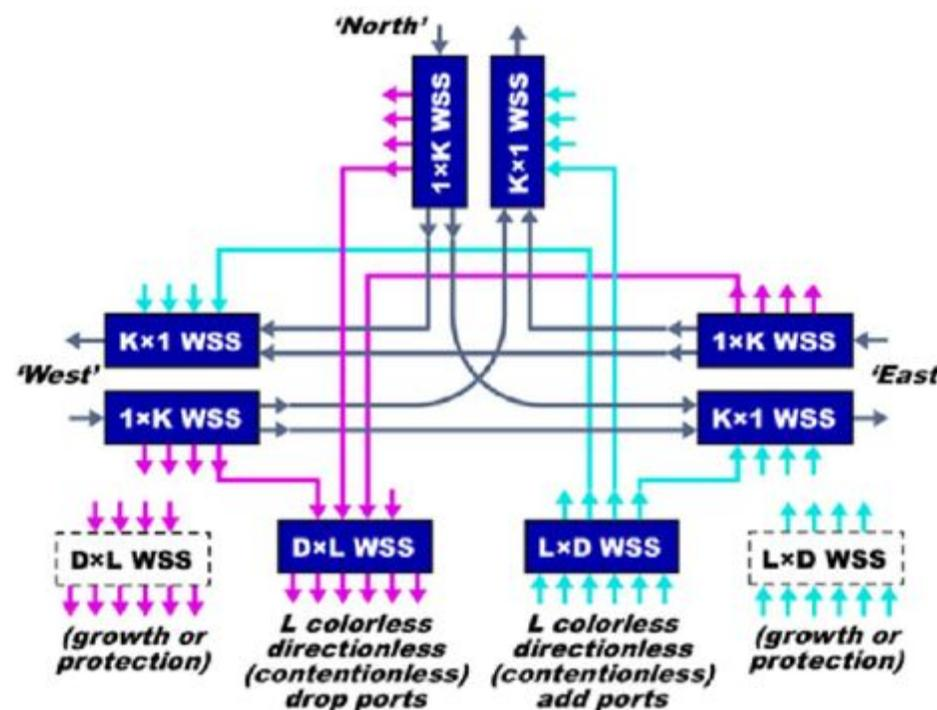
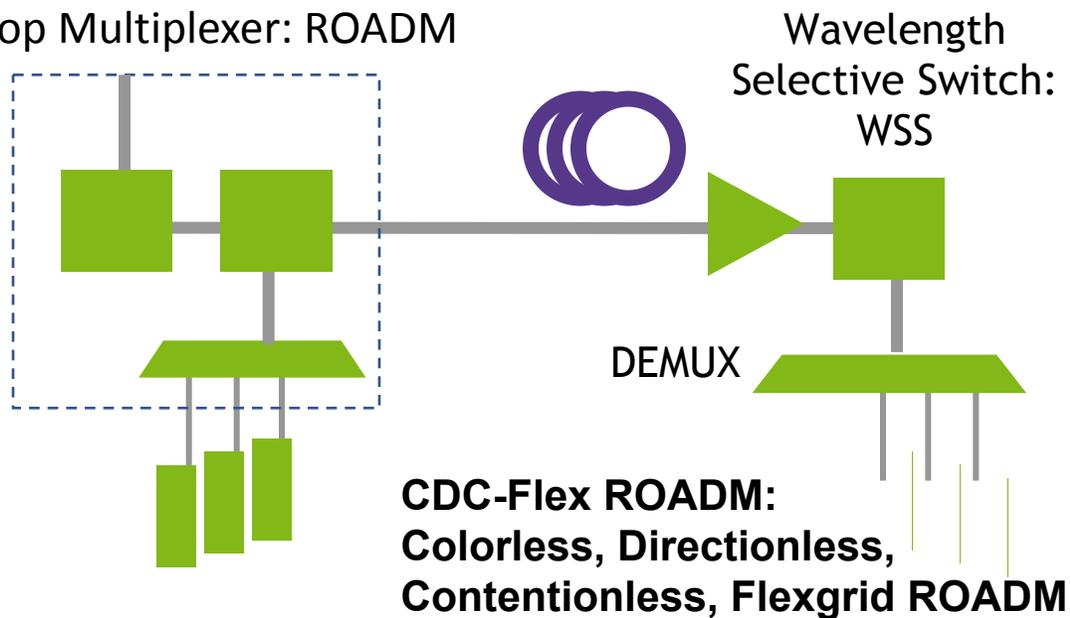

Wavelength Selective Switch (WSS):

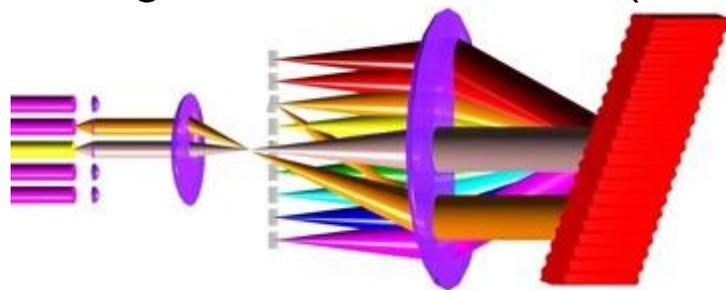

Egress Traffic



Ingress Traffic



Classical optical network designs

- WDM/ROADM

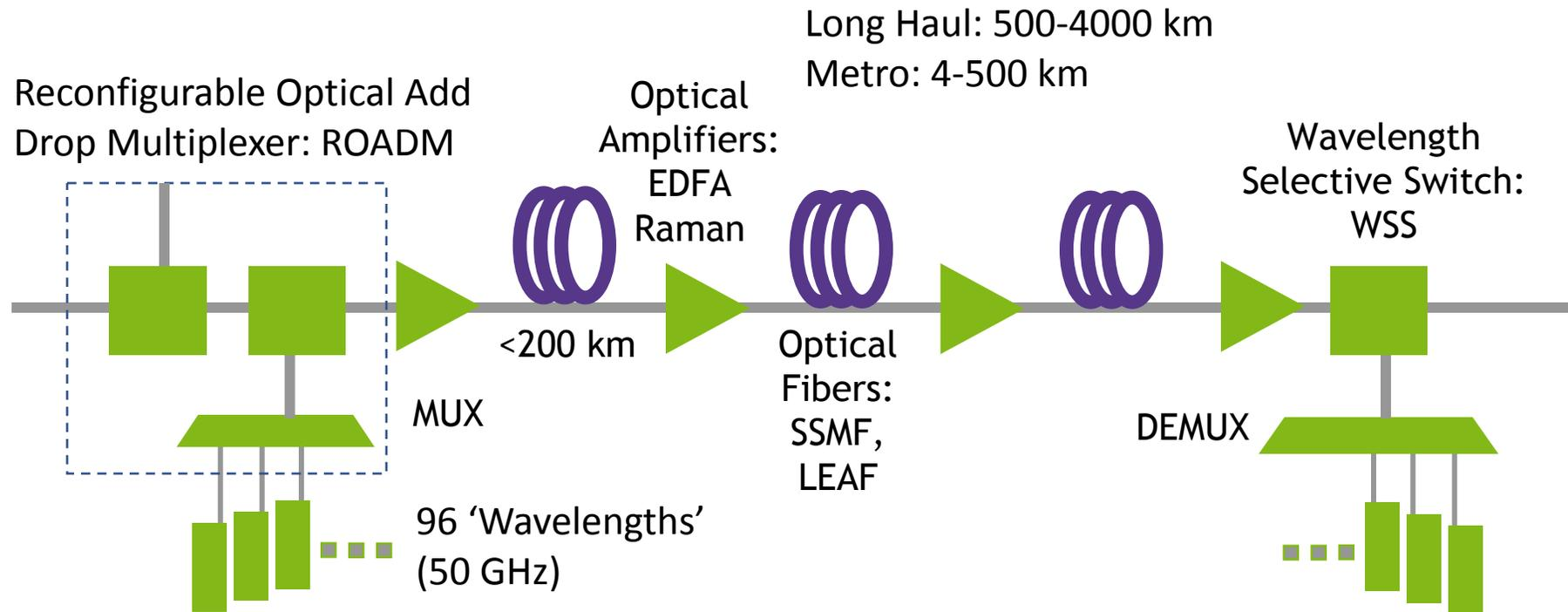

Classical optical network designs

- Passive Optical Networking (PON) systems

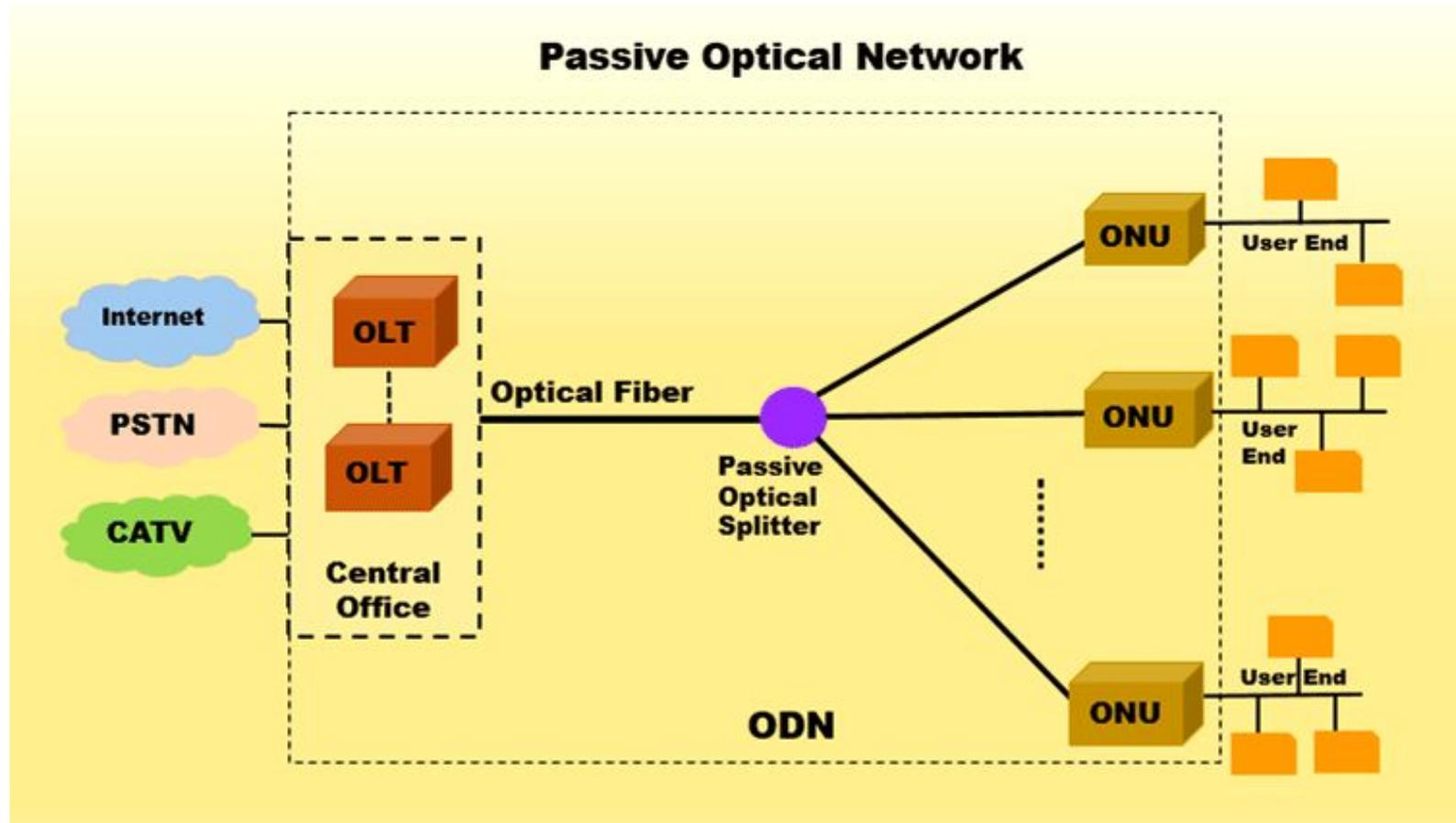

Classical optical network designs

- Optical interconnects
- Data center networks

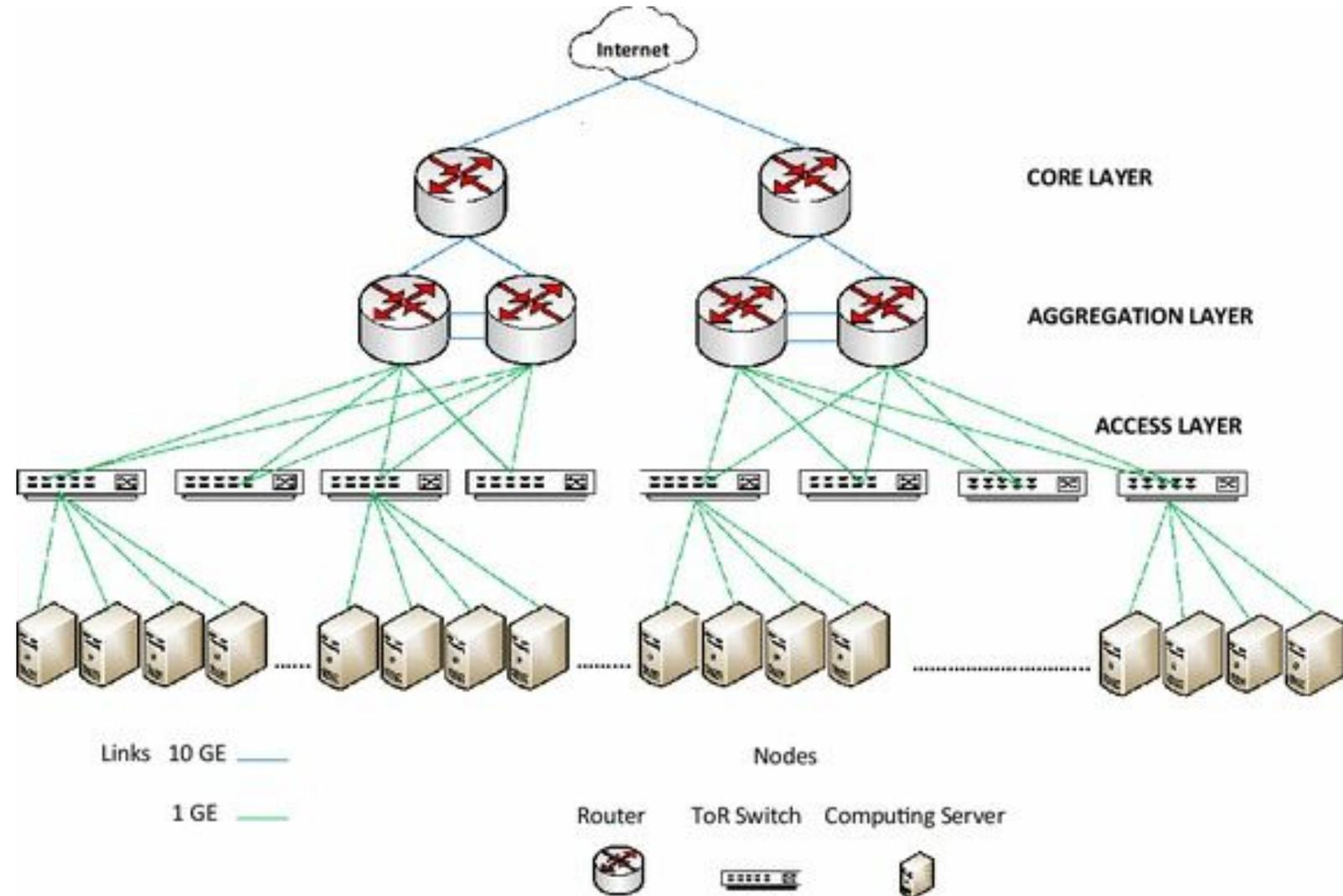
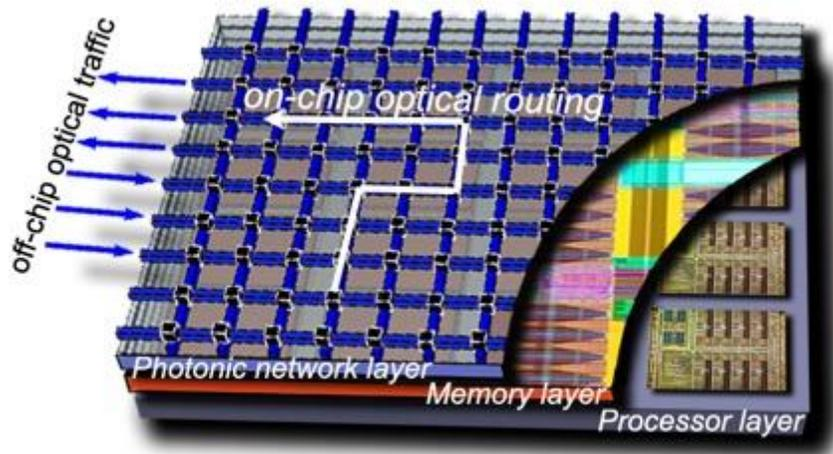

Communication systems and network engineering

A Few Notes on Classical Optical Networks

- It doesn't matter when bits or photons arrive at nodes nor what their polarization is
 - Clocks are synchronized after demodulation at end points
 - Data is only read at the end points, after full demodulation
- Amplified receivers: only care about the SNR, not the losses
- Control loops maintain optimum launch power into fibre spans for each channel and maintain constant gain in amplifiers
- Bits flow continuously, average optical power per channel is constant
- Optical switches are used to configure the system, not to switch bits (operate on minutes/hours time scales)

RWA (RSA): Routing & Wavelength (Spectrum) Assignment

- How to connect Seattle to NYC?
- Use Quality of Transmission (QoT) estimate to choose route & wavelength

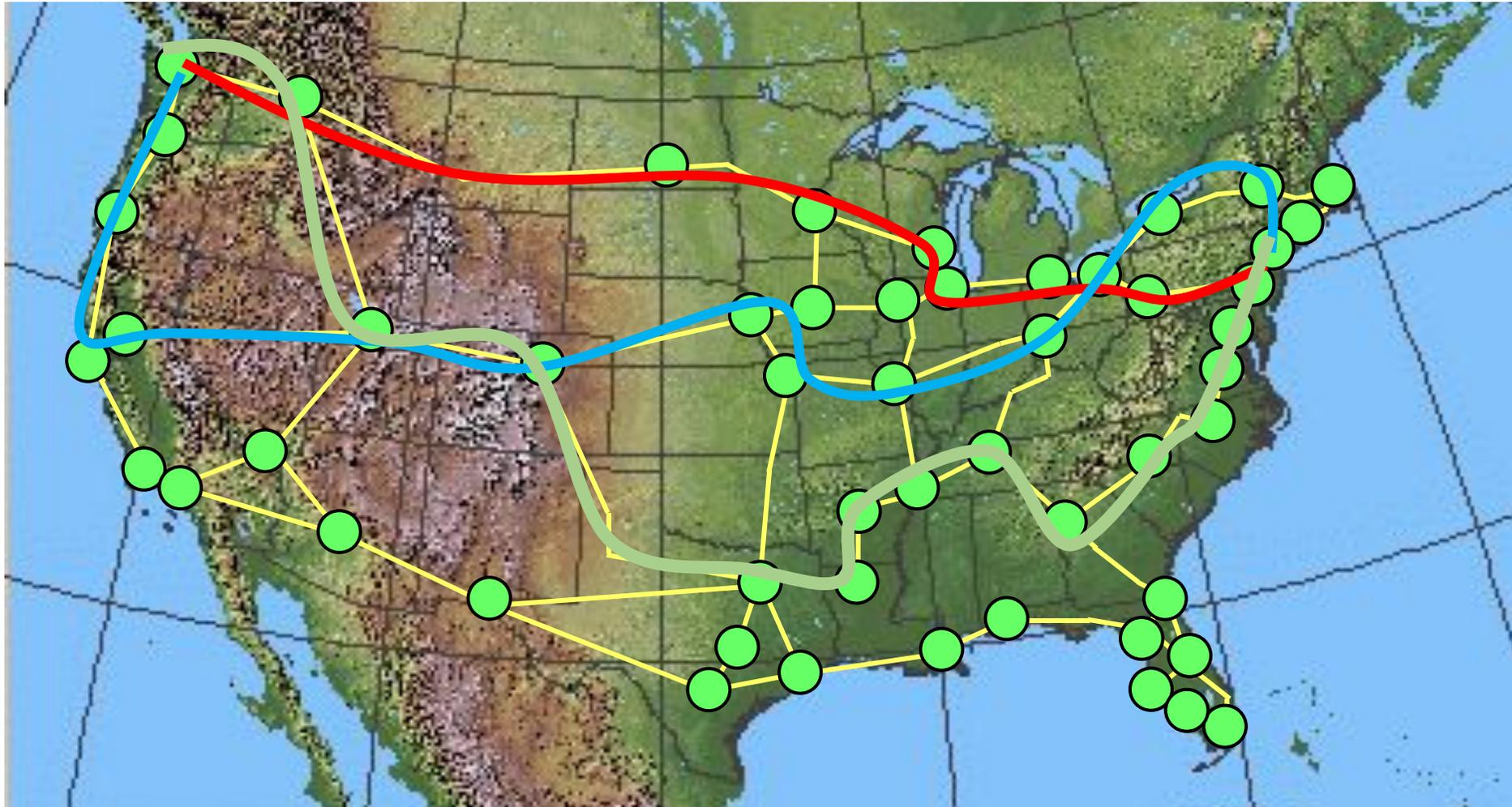

Metro/Regional Network RWA

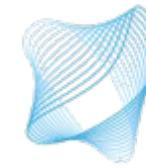

- How to connect Quantum Computers at NIST and DOE?

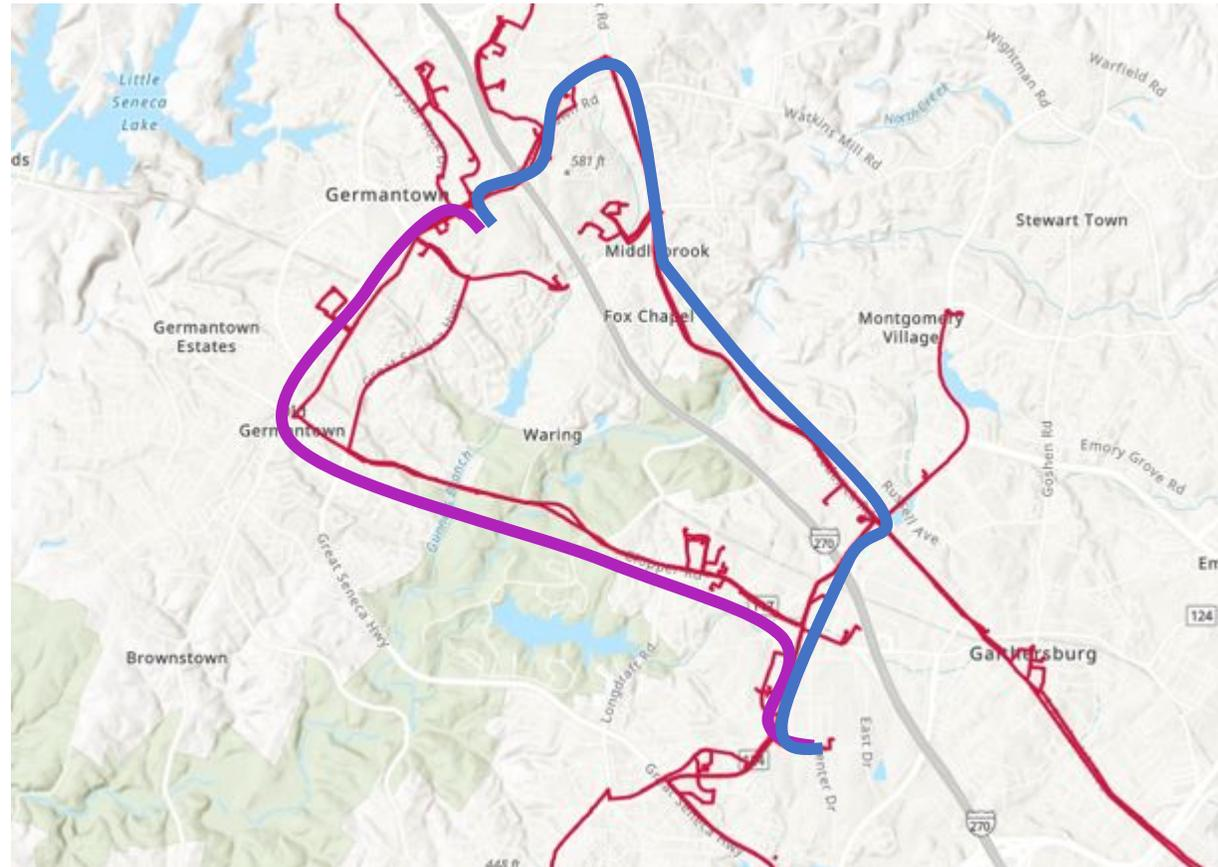

Constraints on Routing Wavelengths



- Wavelength continuity: no wavelength switchers
 - Results in 'wavelength blocking'
- No closed loops: create a laser
- Timing jitter: refractive index variations along fiber
 - Use sync bits in header
- Accumulation of amplifier noise
 - Optical signal to noise ratio
- Nonlinear fiber response
 - Scramble bits to remove pattern effects, keep power low
 - Self-phase modulation (SPM) and cross-phase modulation (XPM)
 - Raman scattering: tilt amplifier gain to compensate
- Other effects:
 - Dispersion: handled by DSP in receiver
 - Polarization dynamics (PDL/PDG): polarization diversity, margins
- Dynamic effects:
 - Optical power dynamics: cross-channel
 - Gain saturation: EDFA & Raman

How dense is WDM?

92x100 Gb/s PM-QPSK + 1 Tb/s Superchannel

800 Gb/s transceivers in commercial production

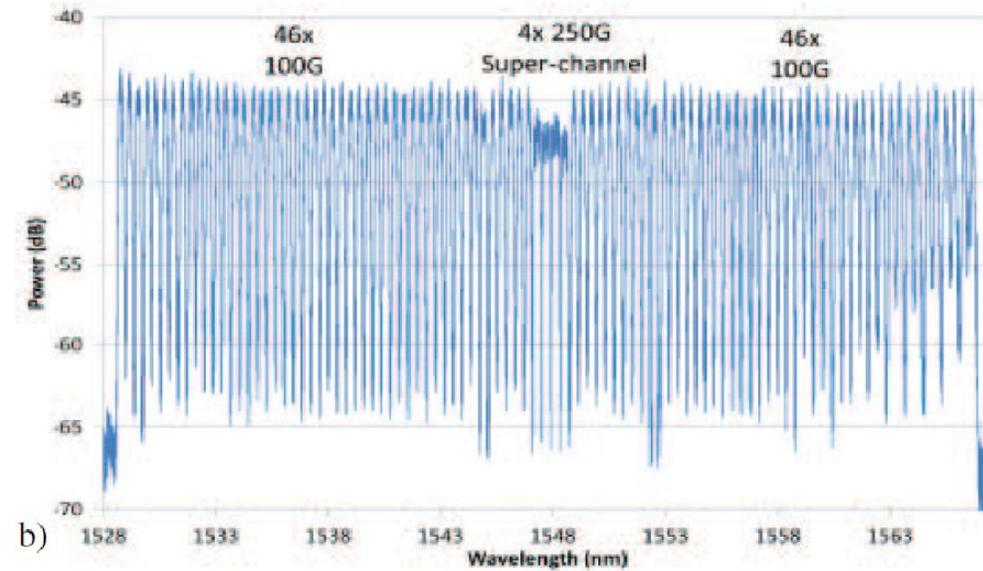
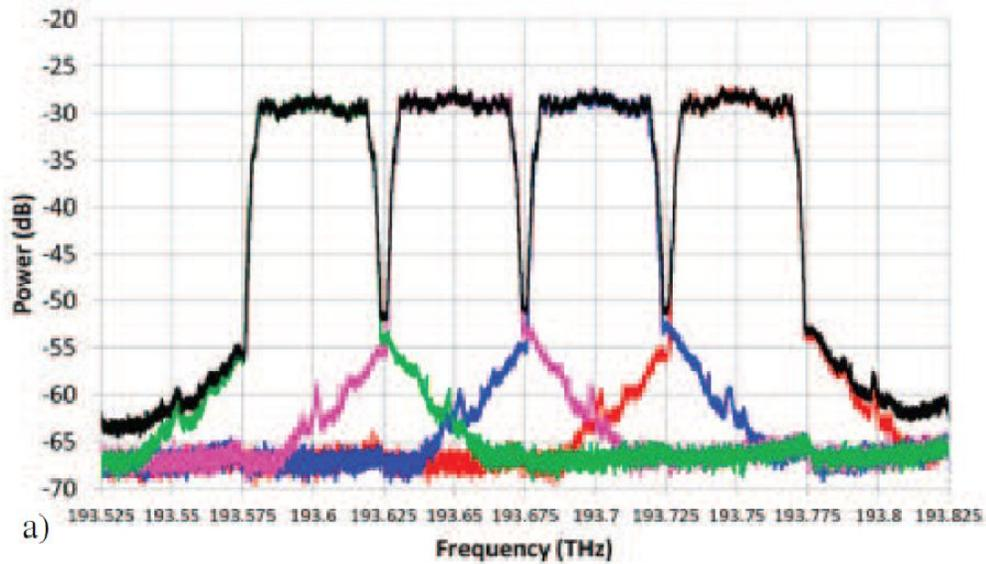

4x40Gbaud 1 Tb/s PM-16QAM Superchannel:

625 km, 6 spans w/ Raman



CFP2-ACO

Fludger, et. al. OFC 2016

Detection Methods

- Direct Detection:



- Coherent or Phase-Sensitive Detection:

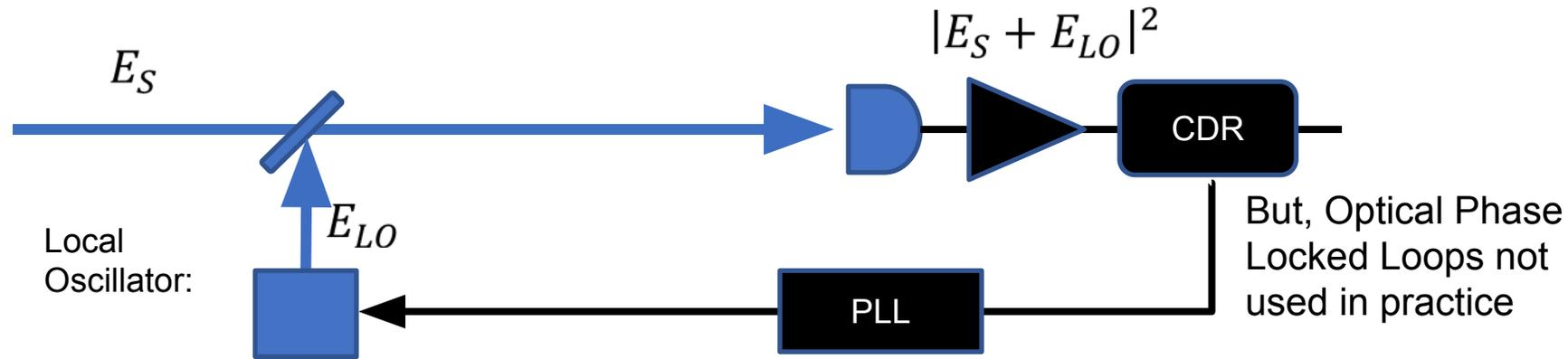

- Problem: After fiber transmission polarization and phase are both rapidly varying!!

Types of Coherent Detection

- Homodyne: Signal and LO are at the same frequency
- Heterodyne: Signal and LO are at different frequencies—create a new signal at frequency difference, ‘IF’: intermediate frequency
- Intradyne: Signal and LO different in frequency by a small amount that can be corrected for in the electronics
 - Use fast digital signal processing (DSP) to track signal phase and frequency
 - DSP provides carrier phase recovery: replaces PLL

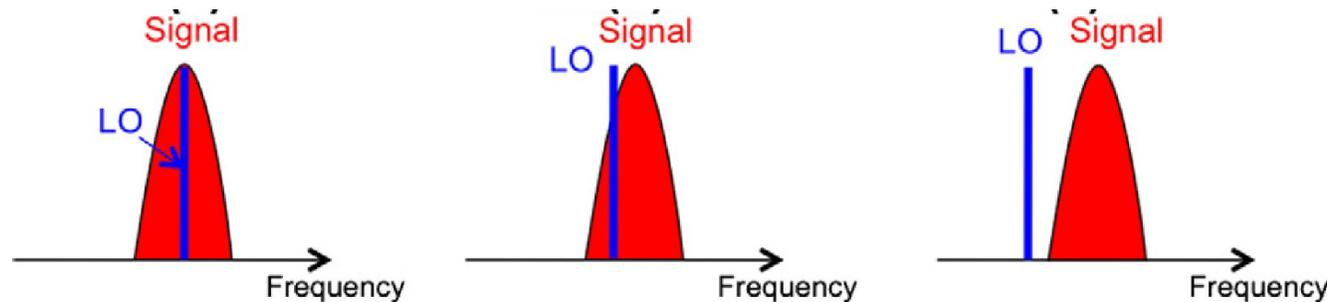

'Coherent Receiver'

- Polarization diversity
- Digital signal processing compensates: (in this order usually)
 - Group velocity dispersion
 - Timing jitter (clock recovery)
 - Polarization drift, PMD
 - Frequency and phase drift (carrier recovery)
 - Some single channel nonlinearities (SPM)

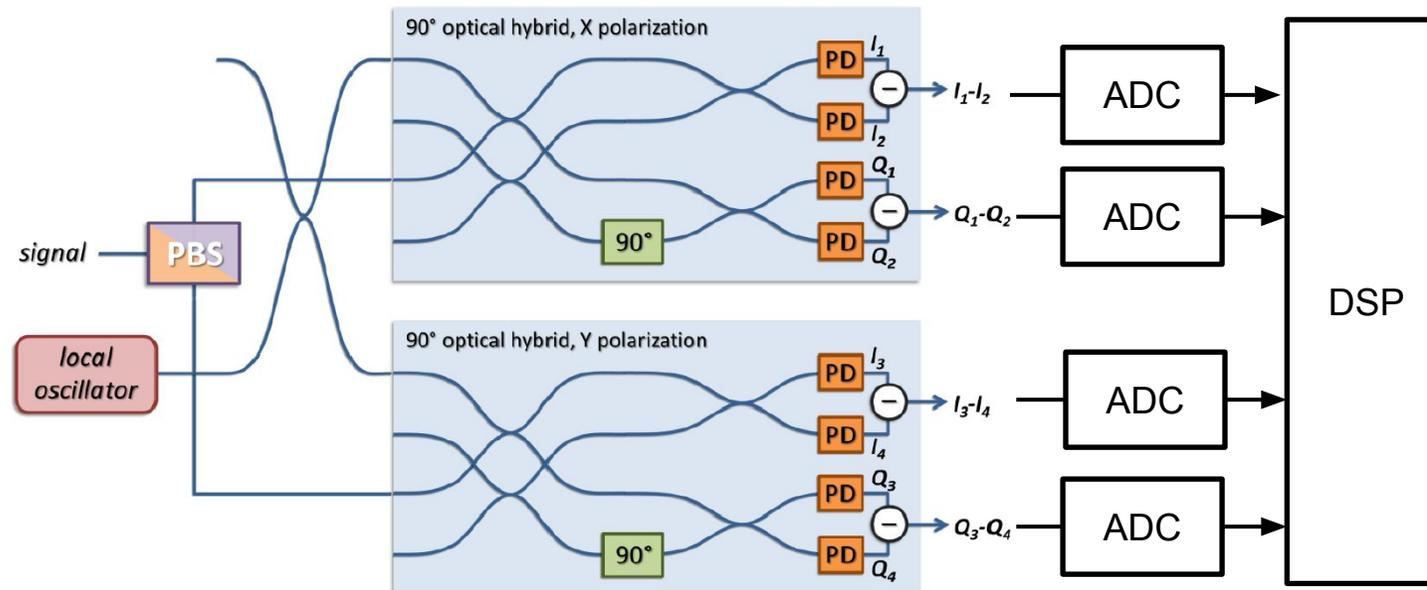

Classical Information Rates

- Bit Rate or Data Rate, R_B
 - Bits refer to binary information

$$R_B = R_S \text{Log}_2 M$$

- Symbol rate (Baud rate), R_S
- M Constellation Points

- Information Rate or 'data rate': R_I
 - Takes into account 'overhead' bits used for forward error correction
 - Actual rate at which application data is transmitted
 - η_c is code rate or fraction of data used for 'information'

$$R_I = R_B \eta_c$$

Spectral Efficiency

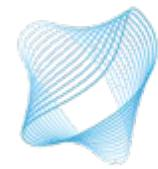

Center for
Quantum
Networks
NSF-ERC



Symbols/Constellations:

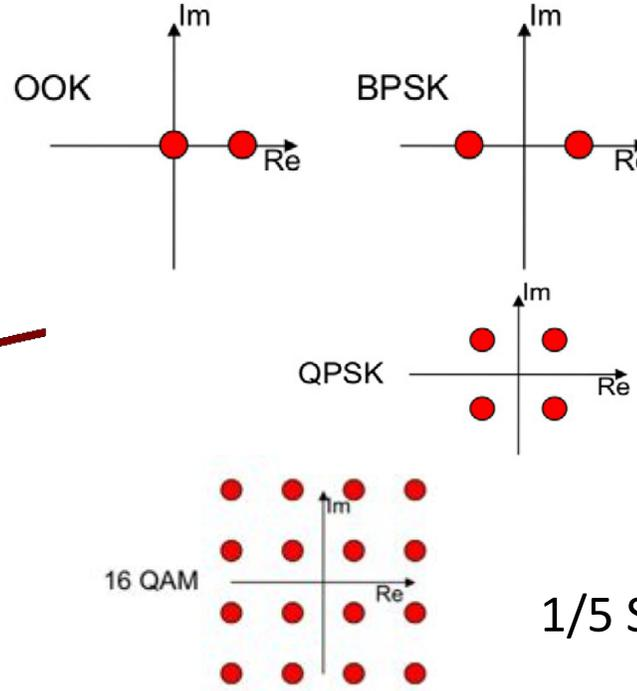

Additive white Gaussian noise channel

$$\frac{C}{W} = \text{Log}_2 \left(1 + \frac{P}{N_0 B} \right)$$

Mod. & Coding

Spectral Efficiency (b/s/Hz)

Shannon Limit

More Bits/
Symbol

Signal to Noise Ratio per Bit

Transmission

OSNR

Baud Rate = Symbol Rate

1/5 S.E.:

10 Gb/s

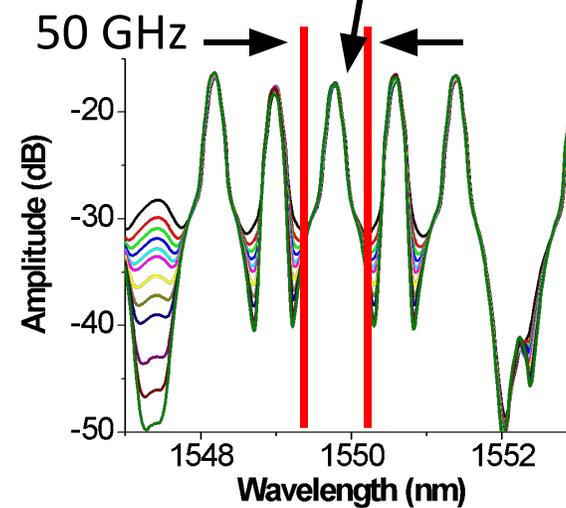

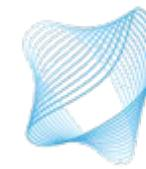

Optical Link: High-Capacity Channel

- Coherent Channel
 - Coherent receiver + Advanced modulation format transmitters

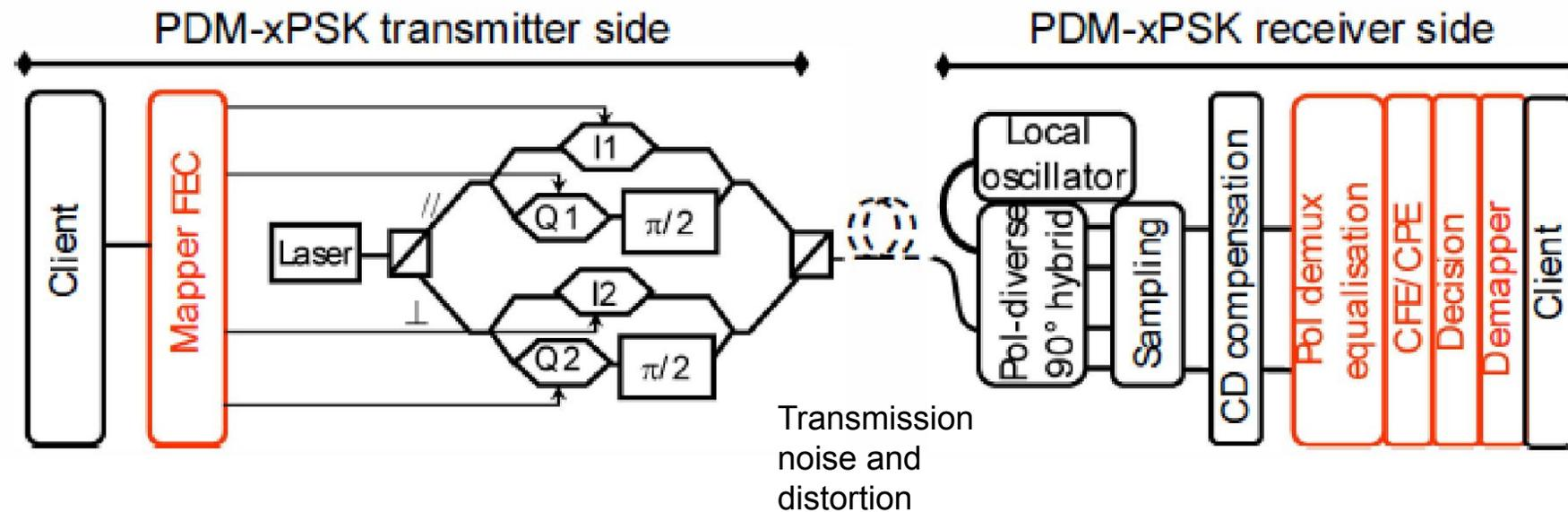

A. Morea ACP

Impaired Constellations

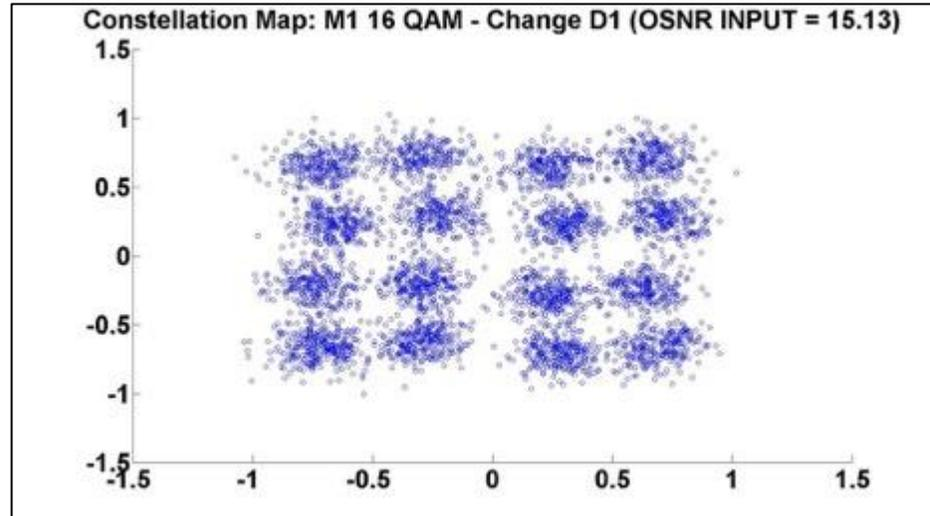

16 QAM: 15 dB OSNR

16 QAM: 16 dB OSNR
Nonlinear Phase Distortion

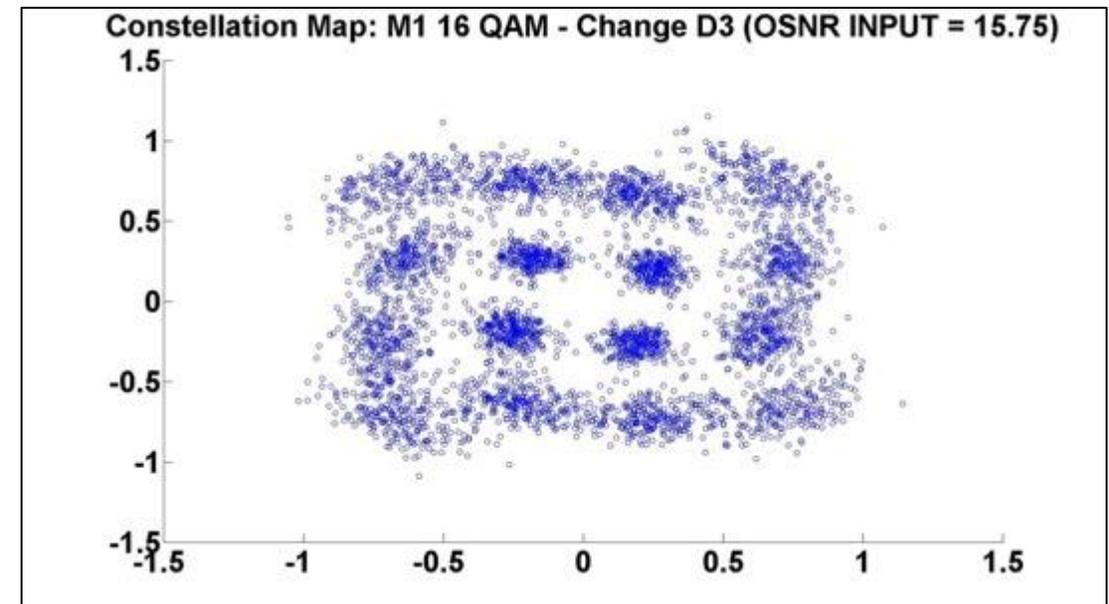

Transmission Reach: Advanced Modulation

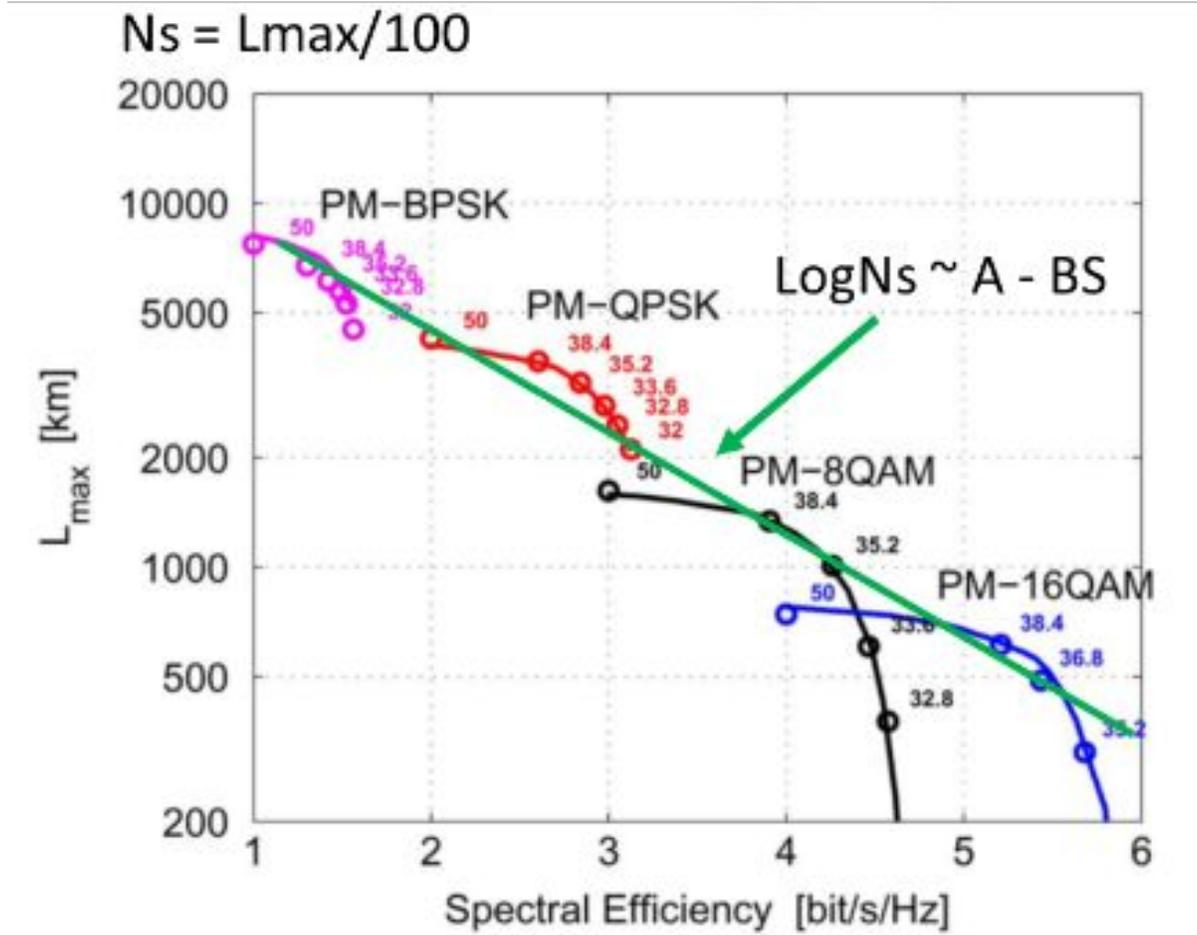

In metro & data center networks:
Distance = # Hops
2000 km ~ 20 hops

Variations in the Field

- Production system measurements
- Performance varies by wavelength & route over time

Wavelength & Route Dependence:

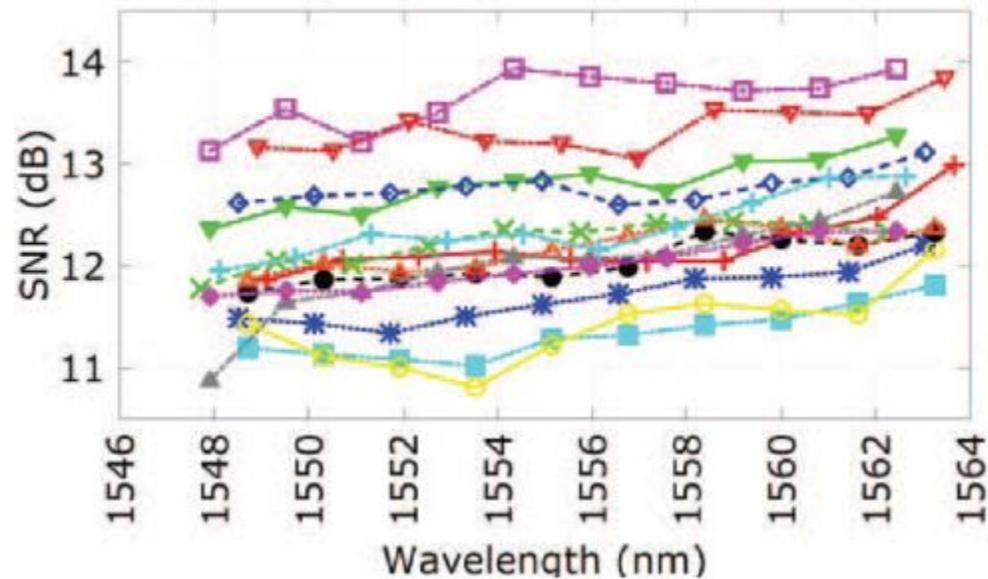

Time Dependence:

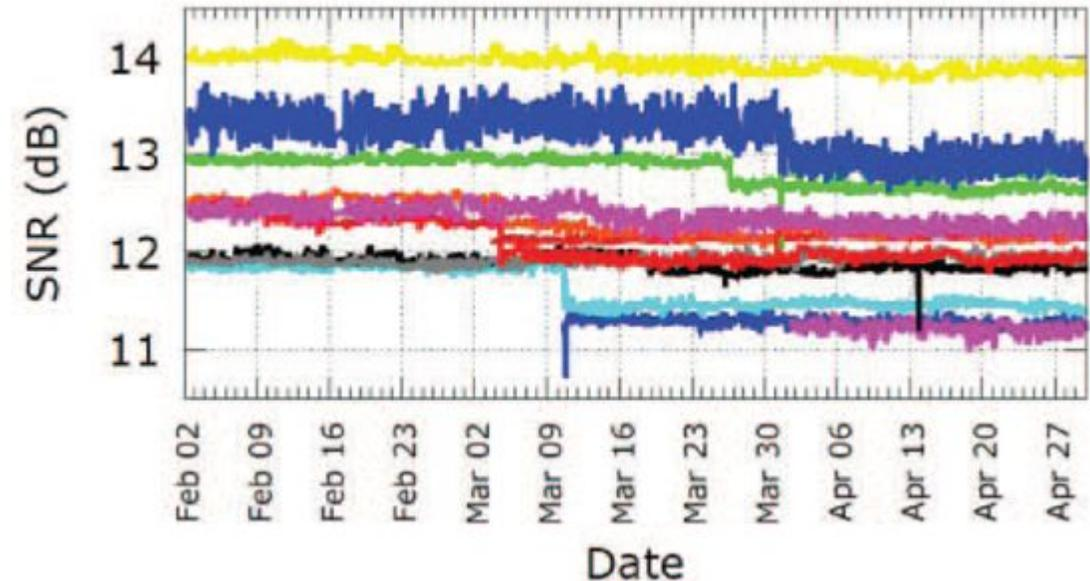

Ghobadi, et. al. OFC 2016

MEMS-based Wavelength Select Switch

Technology for Transparent Networks

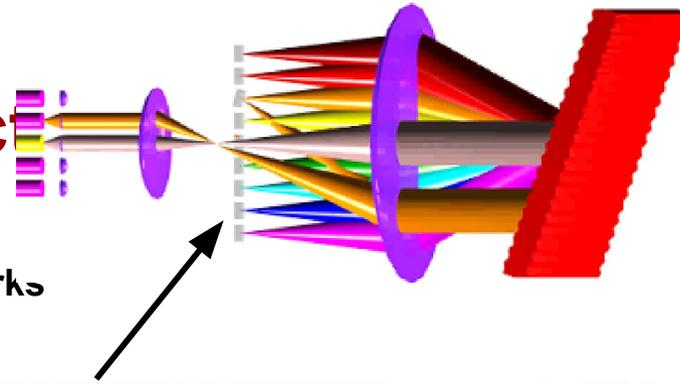

packaged switch assembly

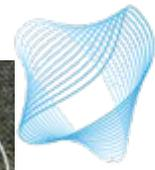

Center for
Quantum
Networks
NSF-ERC

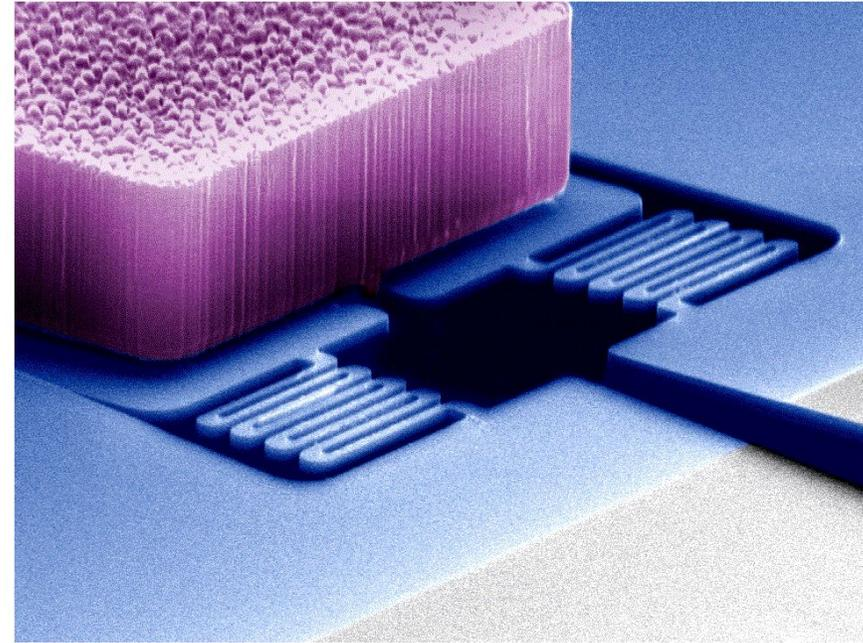
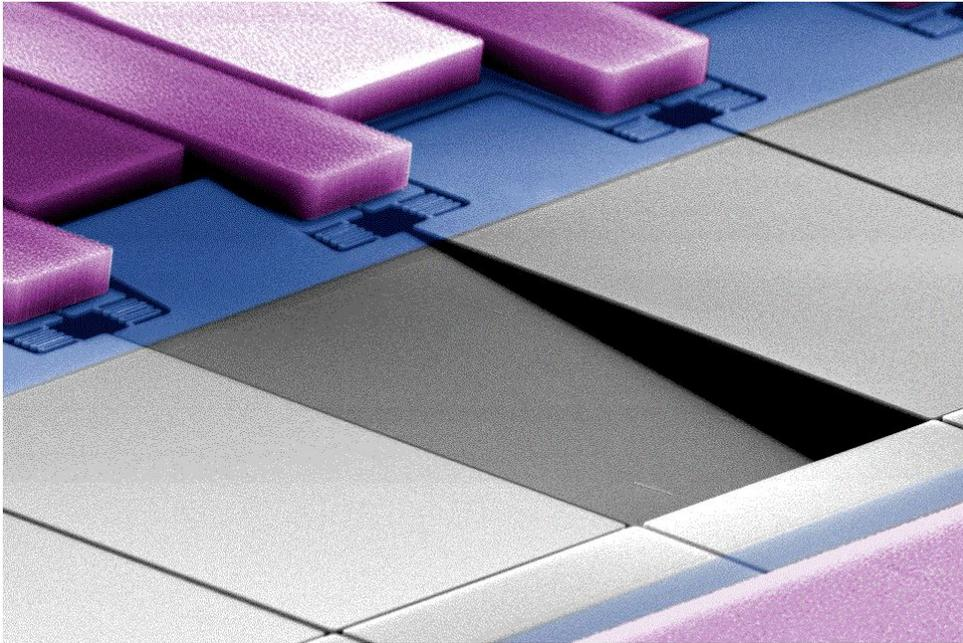

Linear Array of Mirrors

MEMS capabilities enable broad design scope for optical switch technology; Images courtesy of D. Marom

Optical Space (Fiber) Switch

- MEMS-based
- Calient S320:
 - 320 bi-directional ports
 - 45 W total
- Using 100 Gb/s:
 - 1.4 pJ/bit
 - 5 ns delay
- Insertion Loss:
 - 3.5 dB loss fiber to fiber



MEMS Mirrors

Plate Actuators (ramped or flat electrodes)

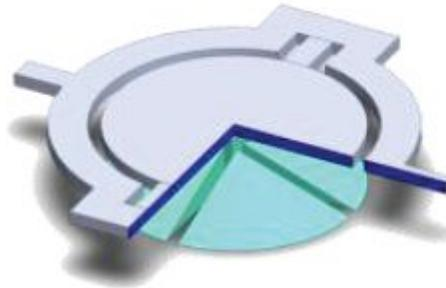

Hidden Springs

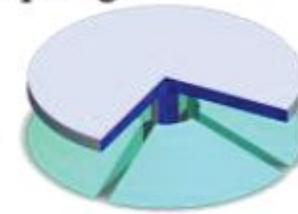
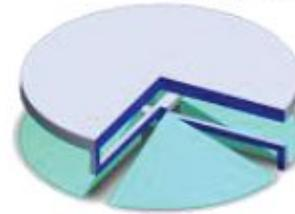

Comb Actuators

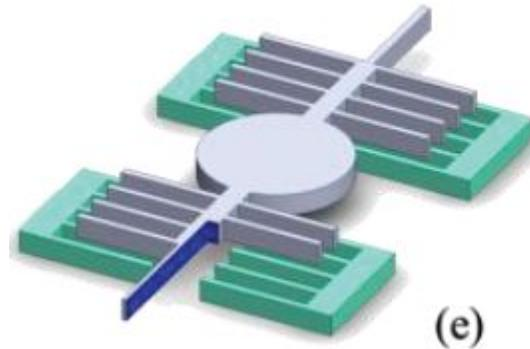

(e)

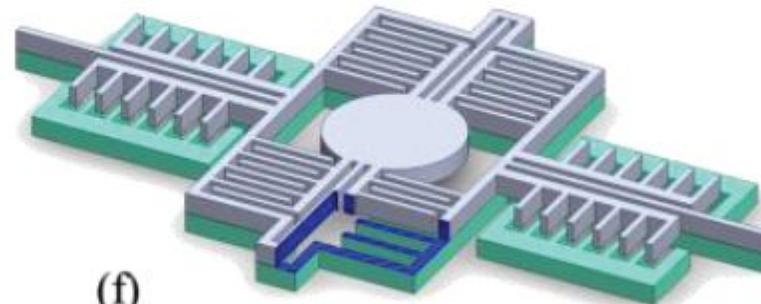

(f)

2D vs 3D

- 3D MEMS allow for NxN switch fabrics
 - Require mirror position holding
 - Often use active feedback and dithering to reduce loss to fiber
 - Mirror holding reduces speeds to \sim ms or longer
- 2D MEMS provide on/off switching
 - Use high voltage to move mirror rapidly: \sim microseconds
 - Use diffraction effects as well as reflection

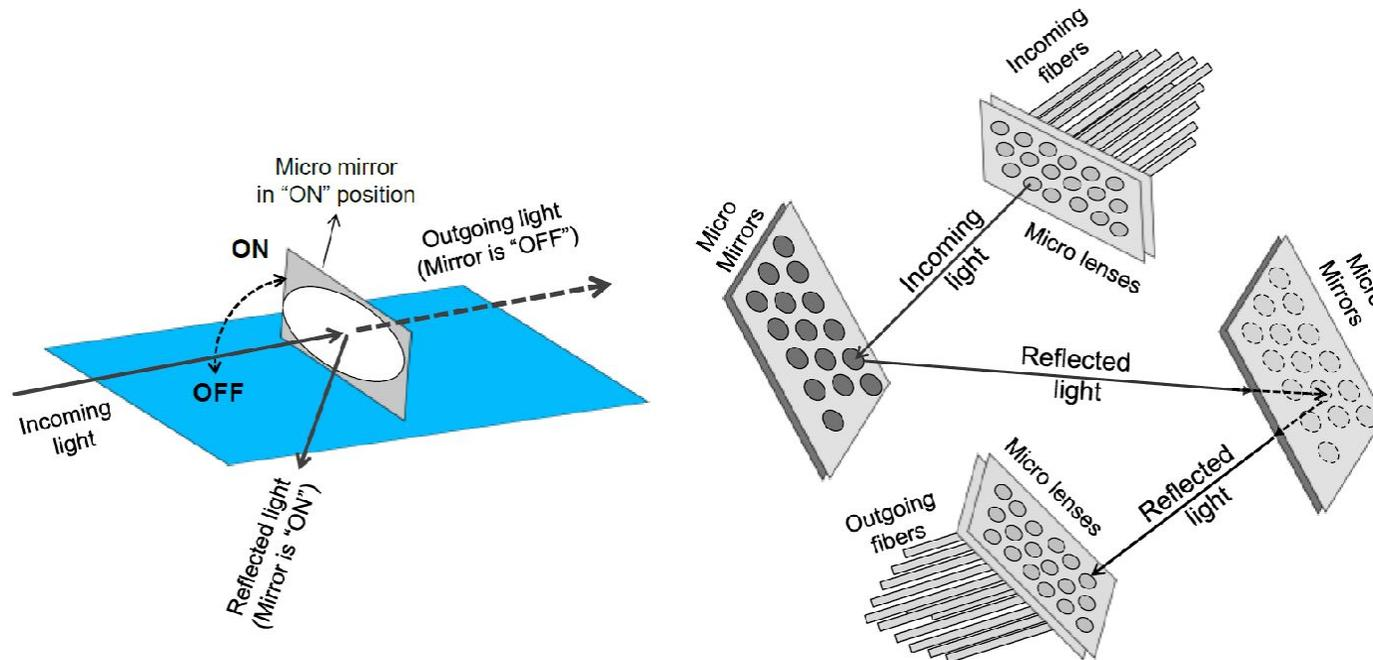

Limits to MEMS Switches

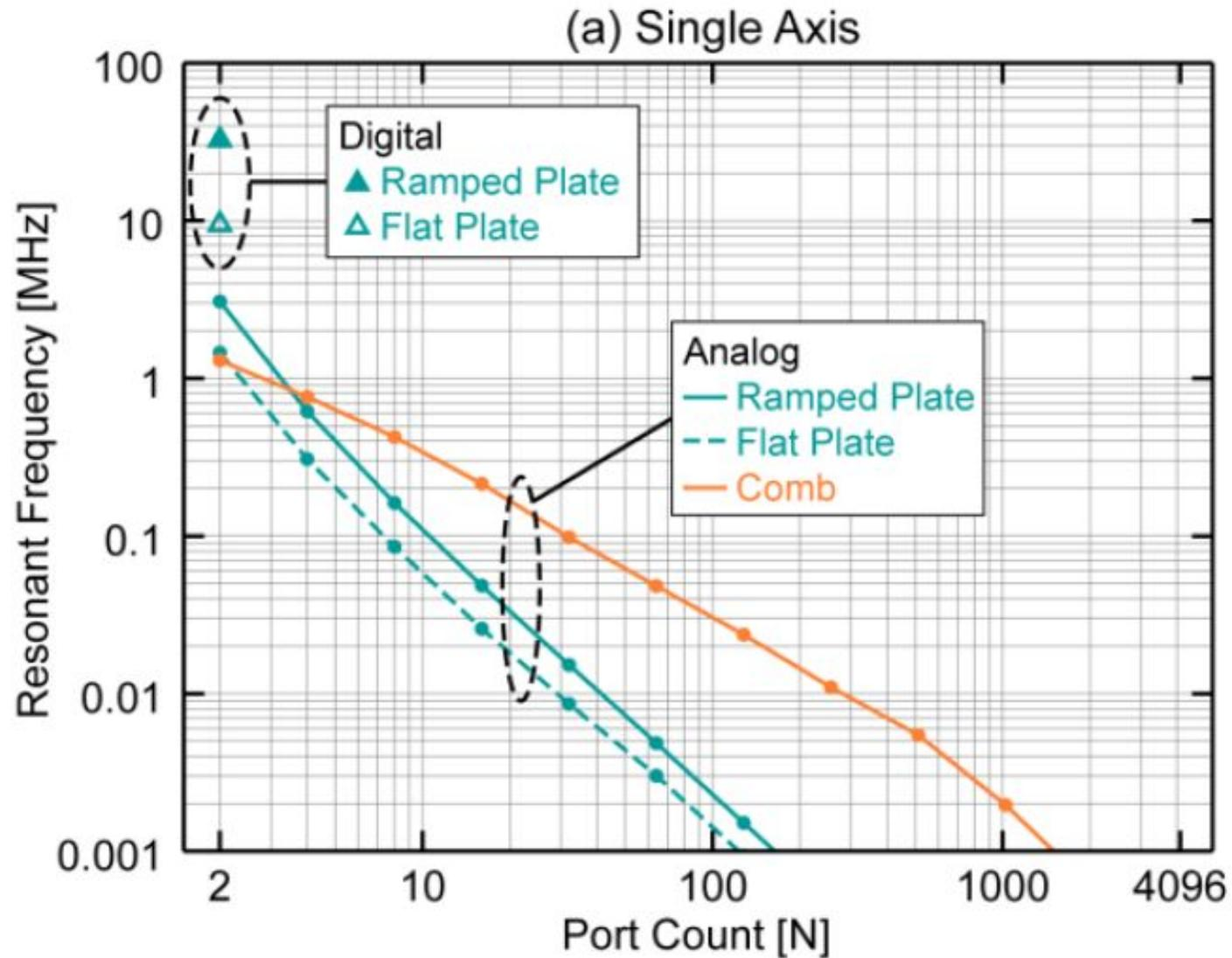

Limits to MEMS Switches

(b) Dual Axis

Same axis
previous slide

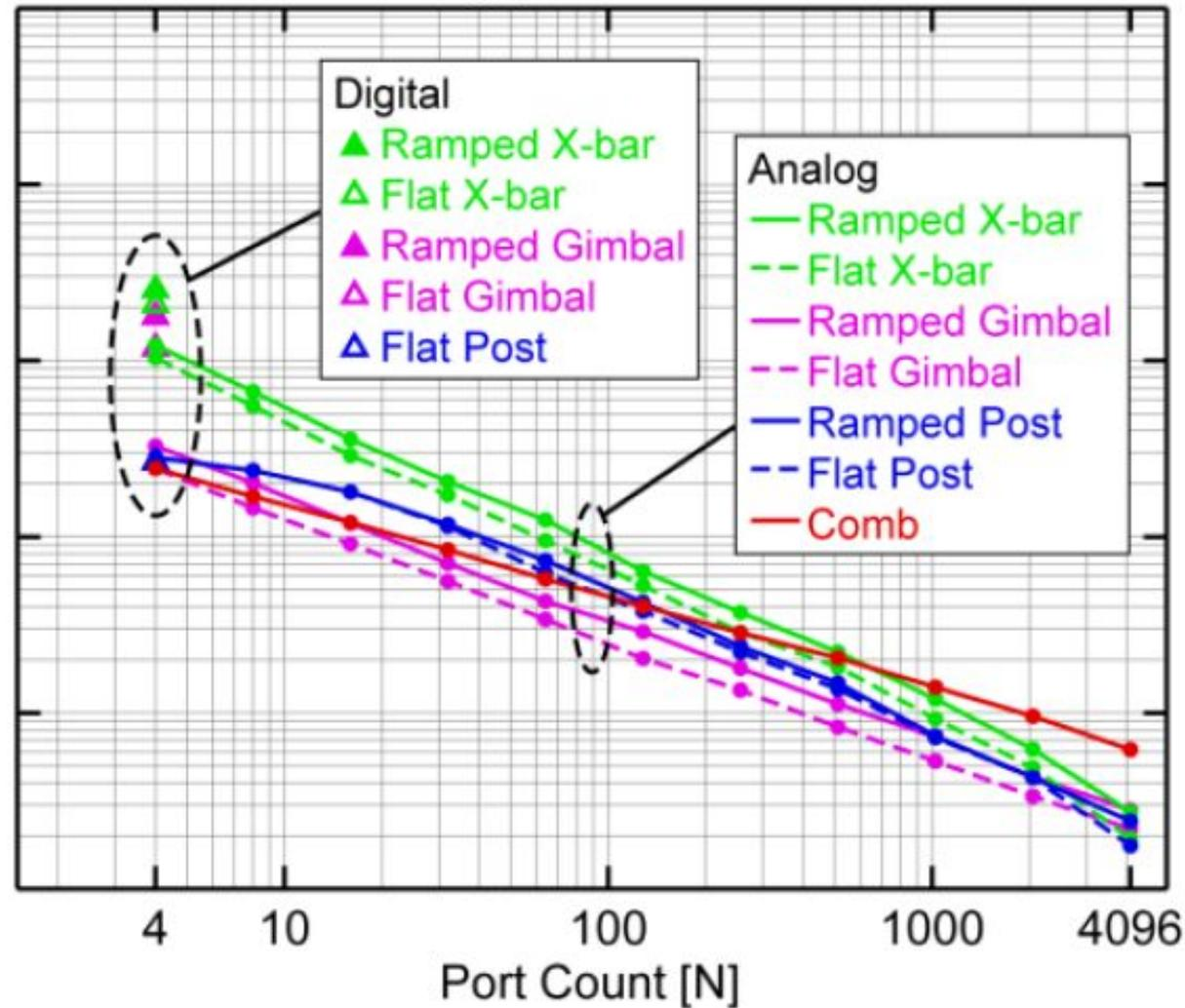

Silicon Photonic MEMS Crossbar Switch

Potential for new
low loss switch
technologies

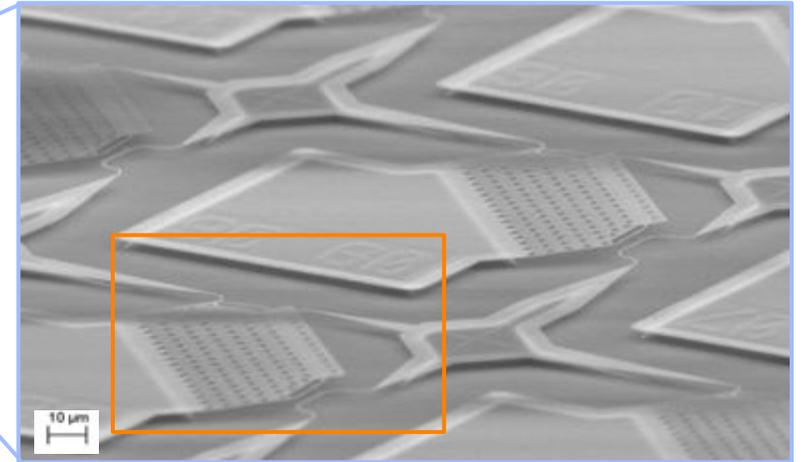
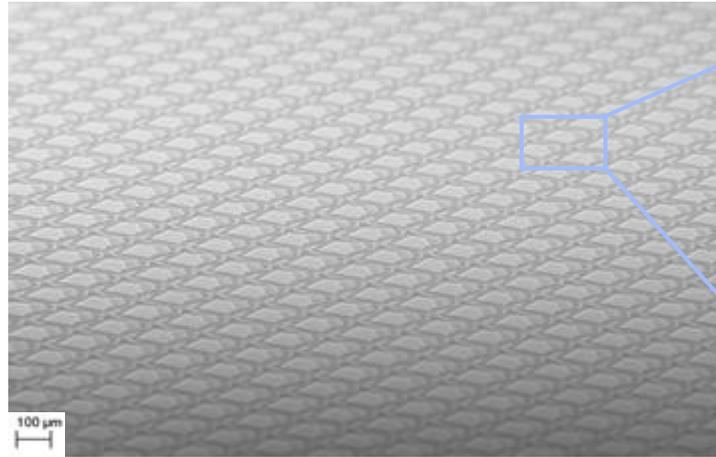

- 2,500 MEMS-actuated switches integrated on 9mm x 9mm chip
- **2.5 μs switching time**
- **OFC 2015: < 1 μs**
- Power losses only during switching
- Energy is in control plane

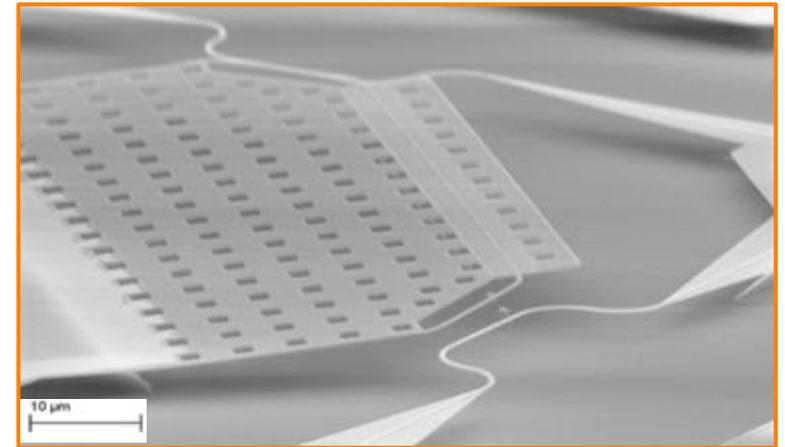

Ming Wu, UC Berkeley

Optical System Control & Management

- Control plane: software controls that actuate system functions, usually 'real time', often autonomous, e.g. IP router control plane
- Management system: operator interface for 'offline' management functions such as maintenance, provisioning, fault isolation, set policy for control plane, etc.
- Intelligent Optical System, Cognitive Optical Networks, Programmable Optical System, Agile Optical Networks, Software Defined Optical Networks: all refer to some form of automated or autonomous control plane operations
 - Current commercial systems are all statically provisioned: no switching

Dynamic Domain Power Control Algorithm

- Power drifts over time and new channels are provisioned: need periodic power control to stay within margins
- Adjust nodes in parallel within 'optically' isolated domains
 - Node ordering based on channel routes

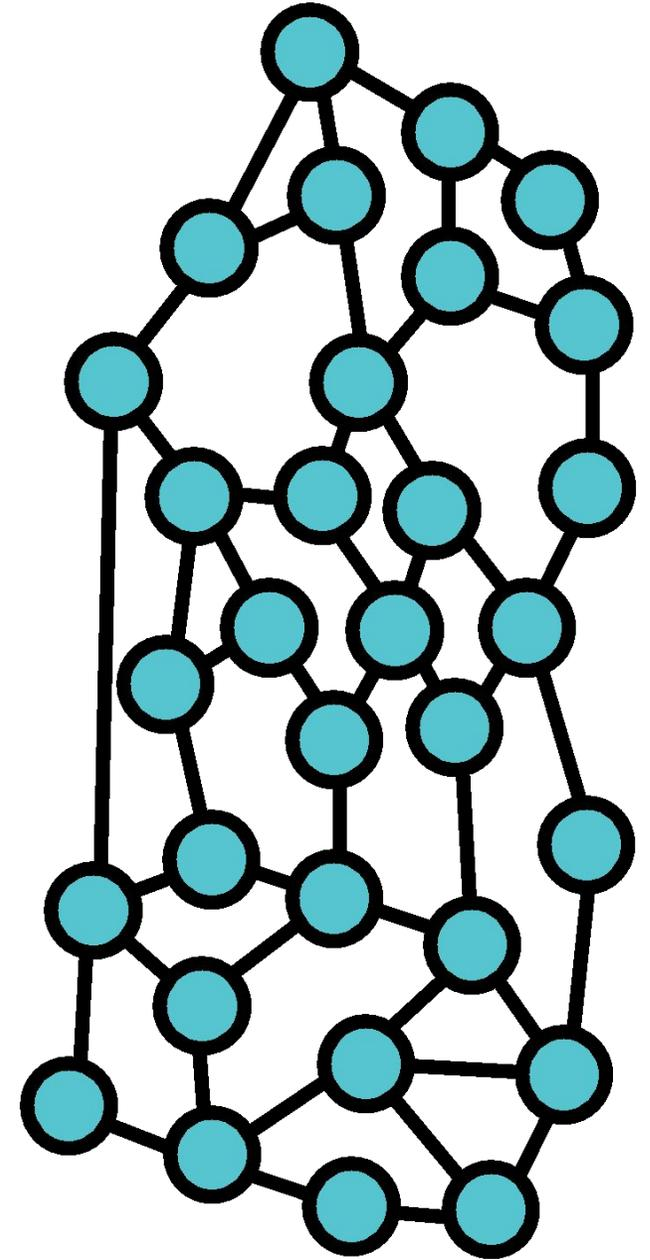
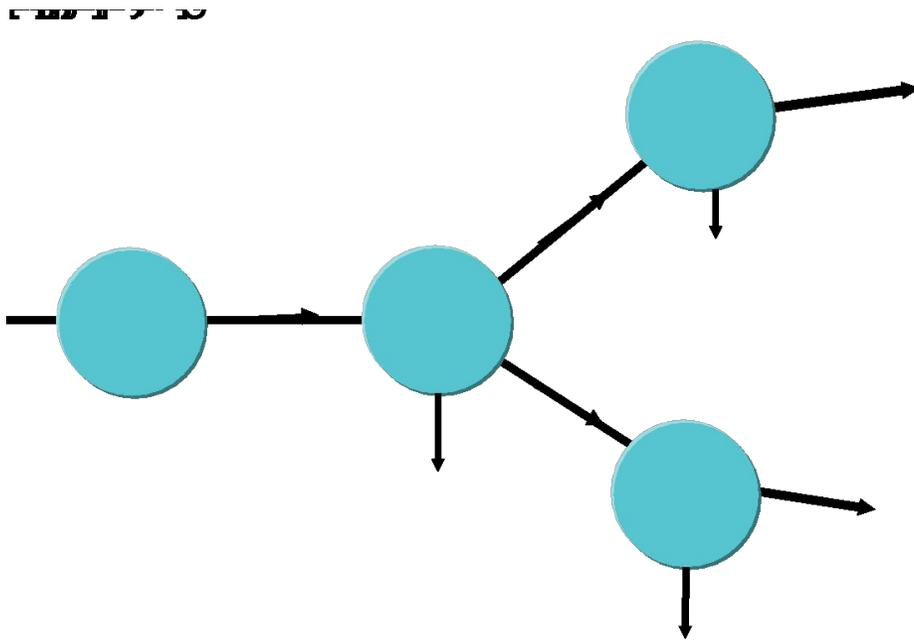

RWA & QoT: How does it work?

- How to connect Seattle to NYC?
- Use Quality of Transmission (QoT) estimate to choose route & wavelength

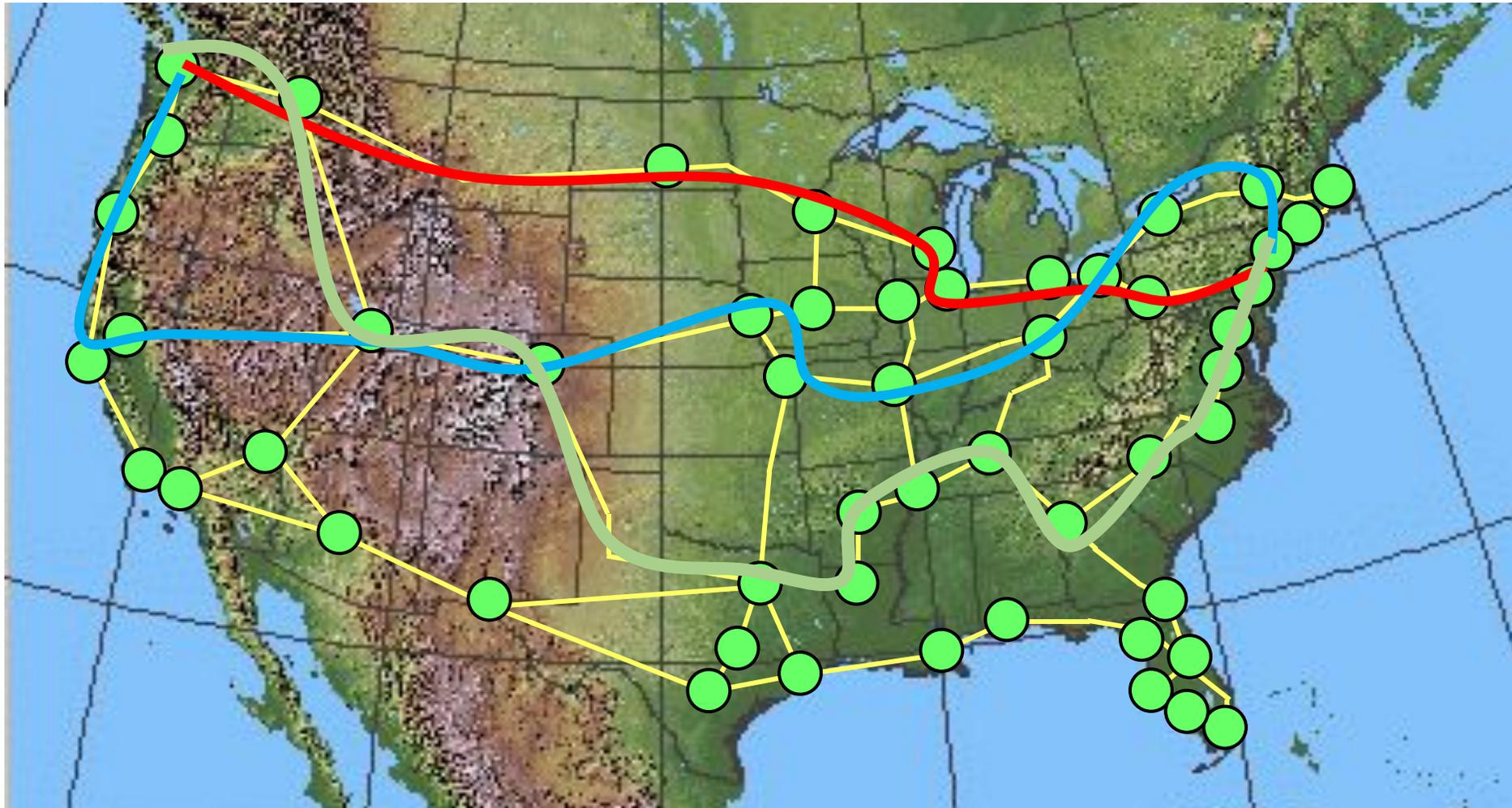

What Determines QoT?

- Generalized Optical Signal to Noise Ratio Metric:

$$gOSNR = \frac{P_{ch}}{P_{ASE} + P_{NLI}} \sim Q$$

$$P_{ASE} = N_{Amp} NF (G - 1) h\nu B$$

$$P_{NLI} \sim N_S^{1+\epsilon} P_{ch} P_I^2$$

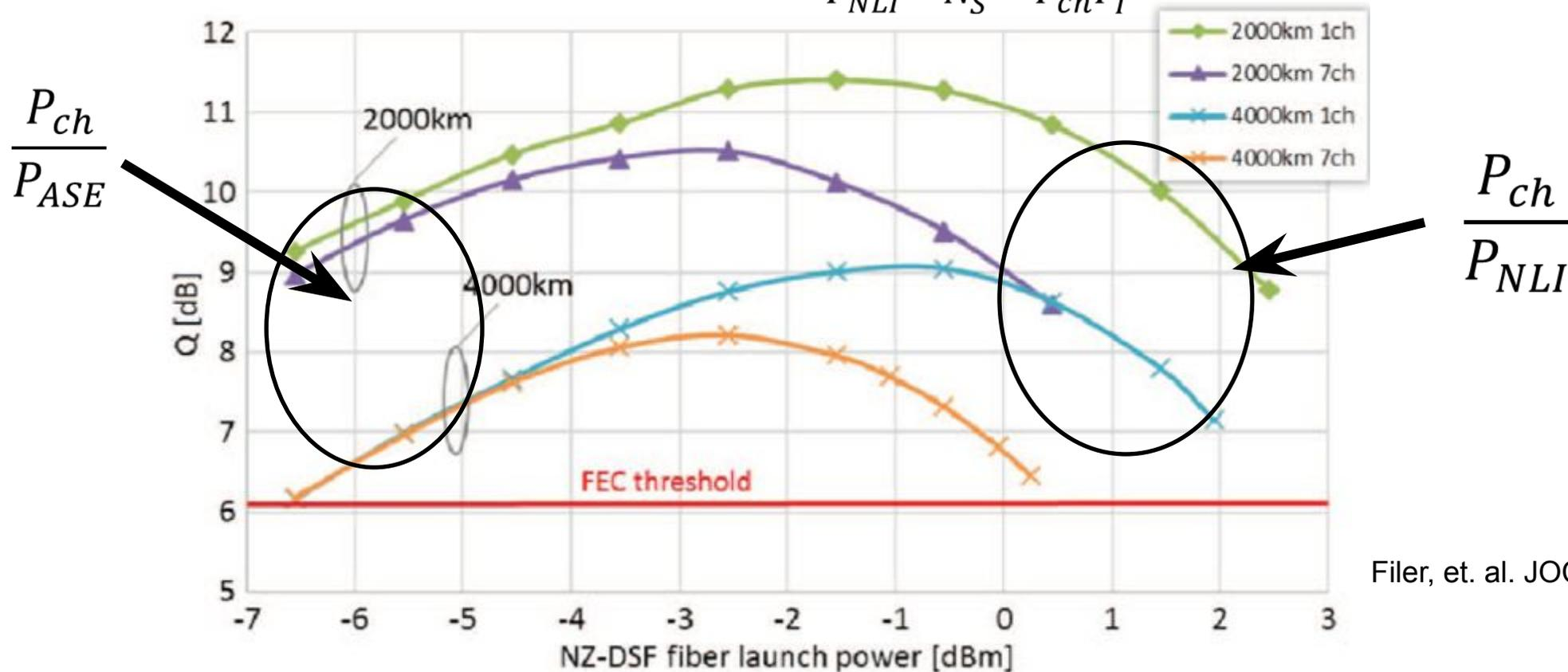

Filer, et. al. JOCN 2016

Q-Factor, Power Dependence

- Optical Q depending on channel config & distance
- $Q \sim \text{SNR}$

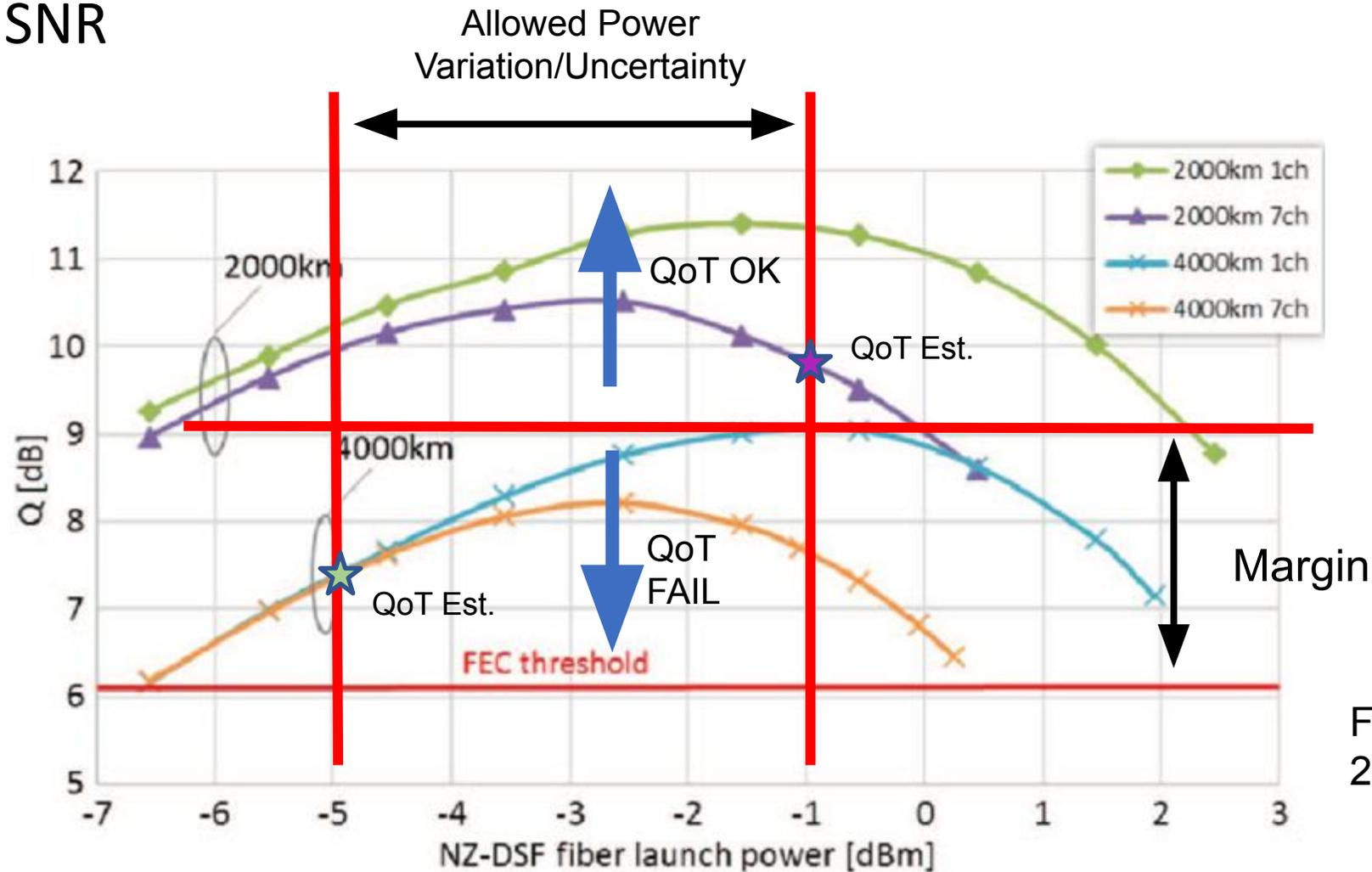

Filer, et. al. JOCN
2016

Generic Wavelength Provisioning Protocol (every vendor has their own protocol)



- Get request for connection between A and B
- Run RWA to determine route and wavelength
 - Estimate QoT to ensure RWA meets performance requirements
- Gradually open up first link and adjust amplifiers and optical powers
 - Gradually open up second link, etc.
 - Freeze or minimize adjustments on other links
- Measure final bit error rate of end-to-end connection
- Let soak for days or weeks
- Add new connection to routing tables to start carrying traffic

Functions of Optical Physical Layer Controllers

- Control diverse set of optical transmission hardware to operate network
 - Provision channels
 - Tune amplifiers
 - Tune channel powers
 - Manage faults, e.g. node loss, transient recovery
 - Tune/control transceivers
- Real time elastic bandwidth/flex grid management
- Real time route selection
- Real time optical circuit switching
- Wavelength layer link/segment protection switching
- Defragmentation
-

**Current
proprietary
solutions**

Future

SDN Across Multi-Domain Networks

Ongoing area of research

- How to route wavelengths through proprietary networks (unknown topology)?
- How to guarantee signal performance?
- How to scale control operations across domains?

Many benefits

- Low-latency, low cost end-to-end optical connections

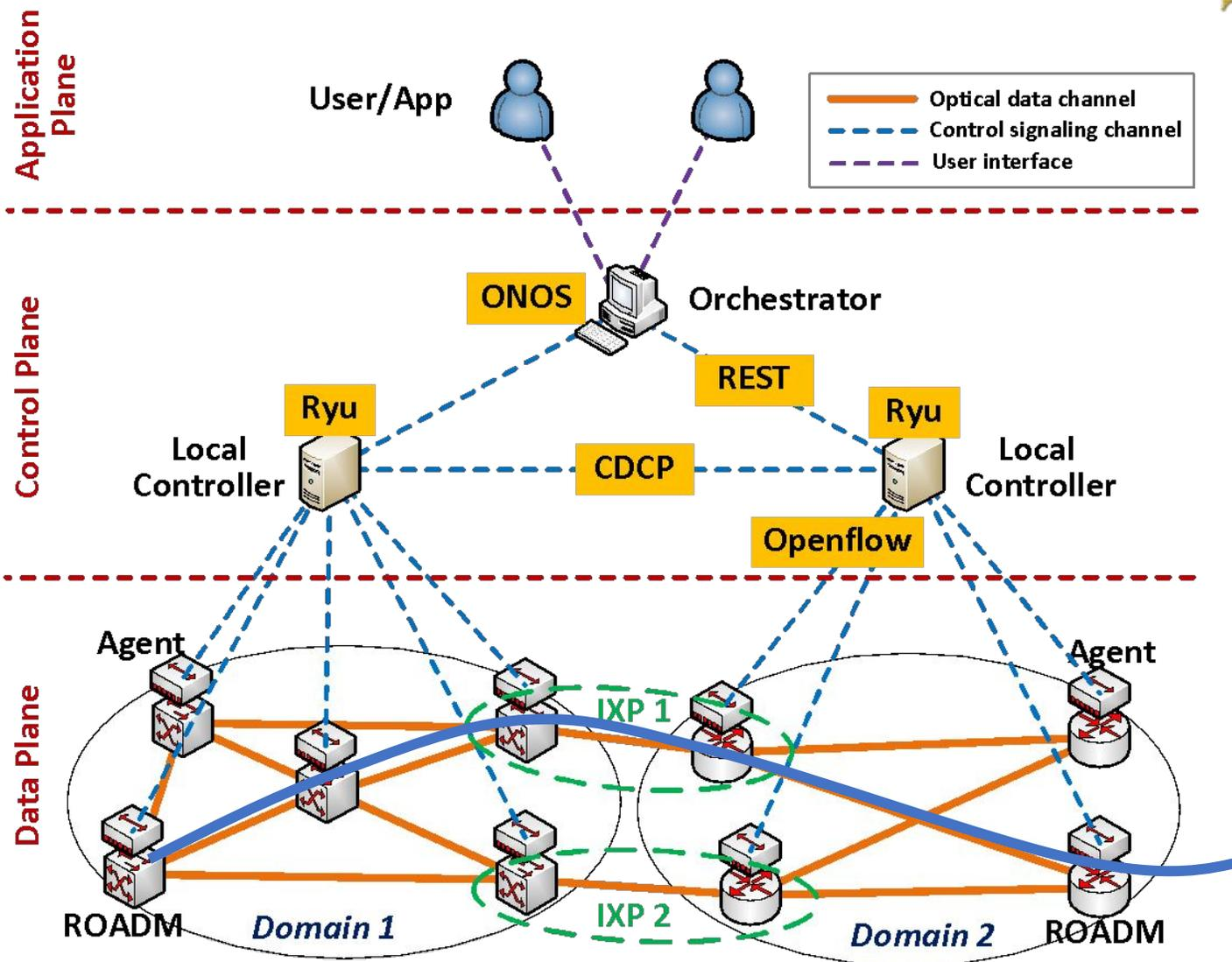

Control Plane Elements

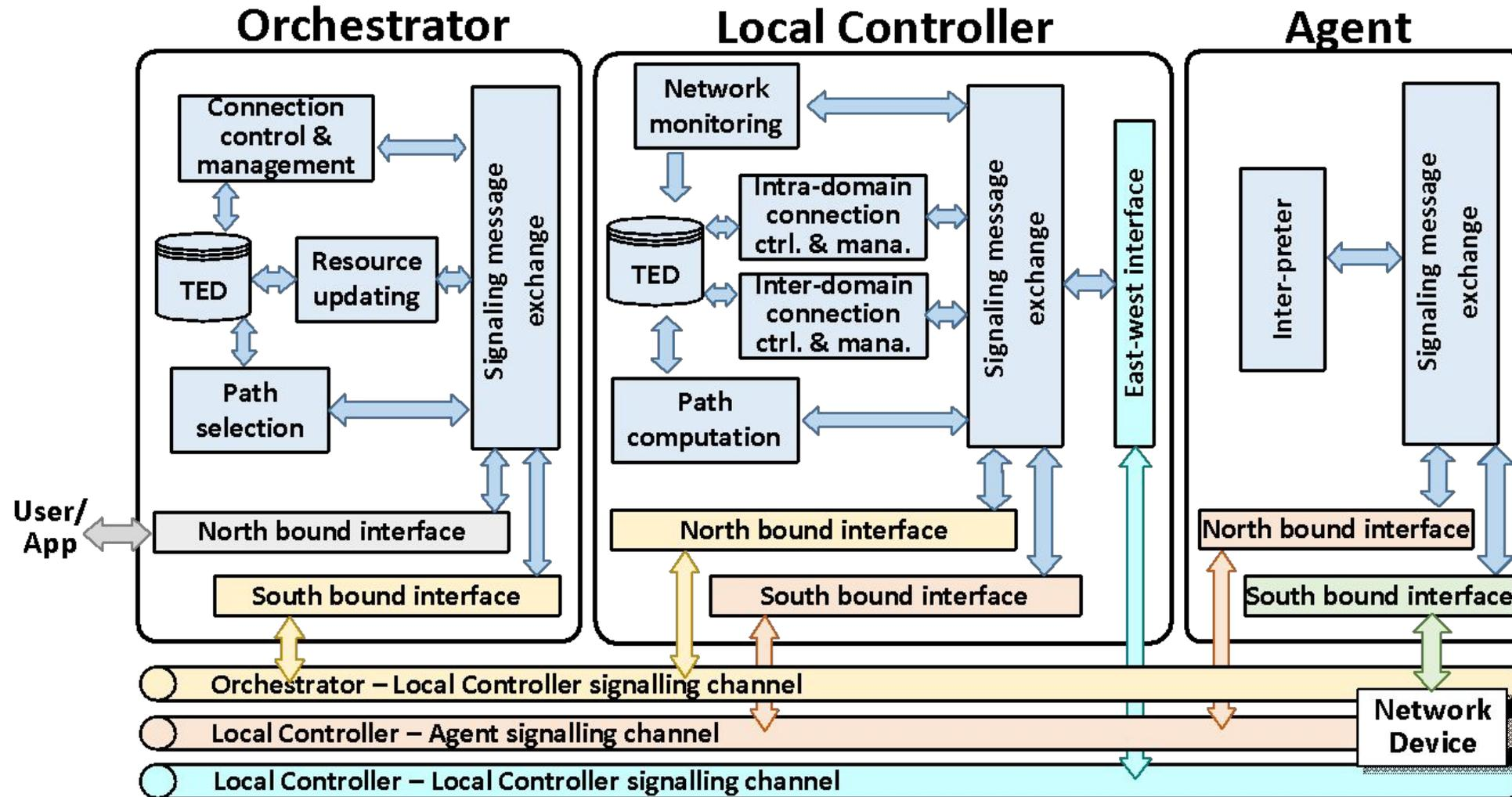

Control and management

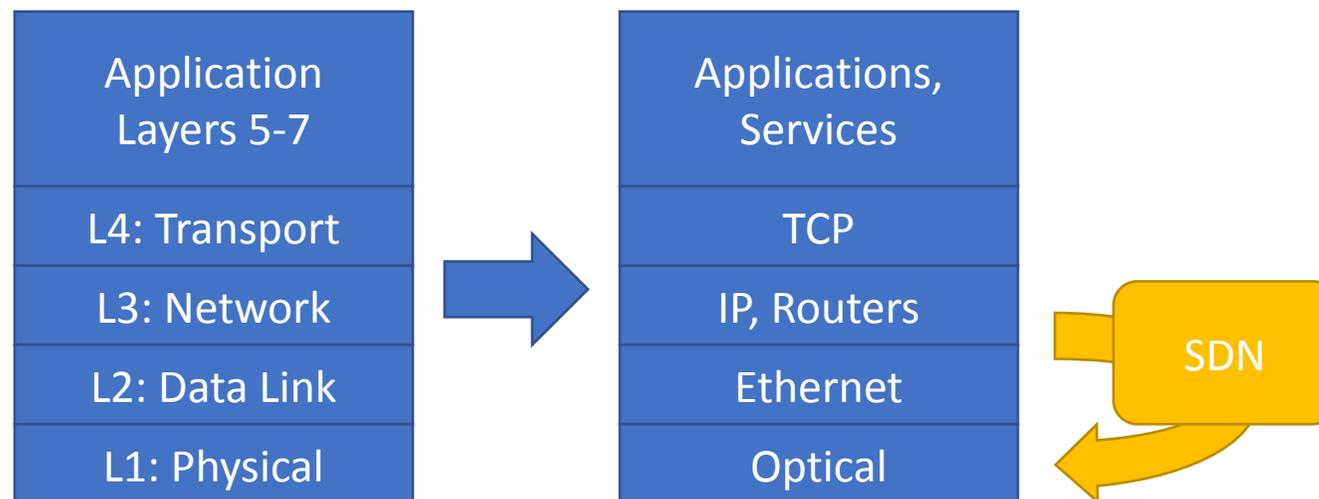
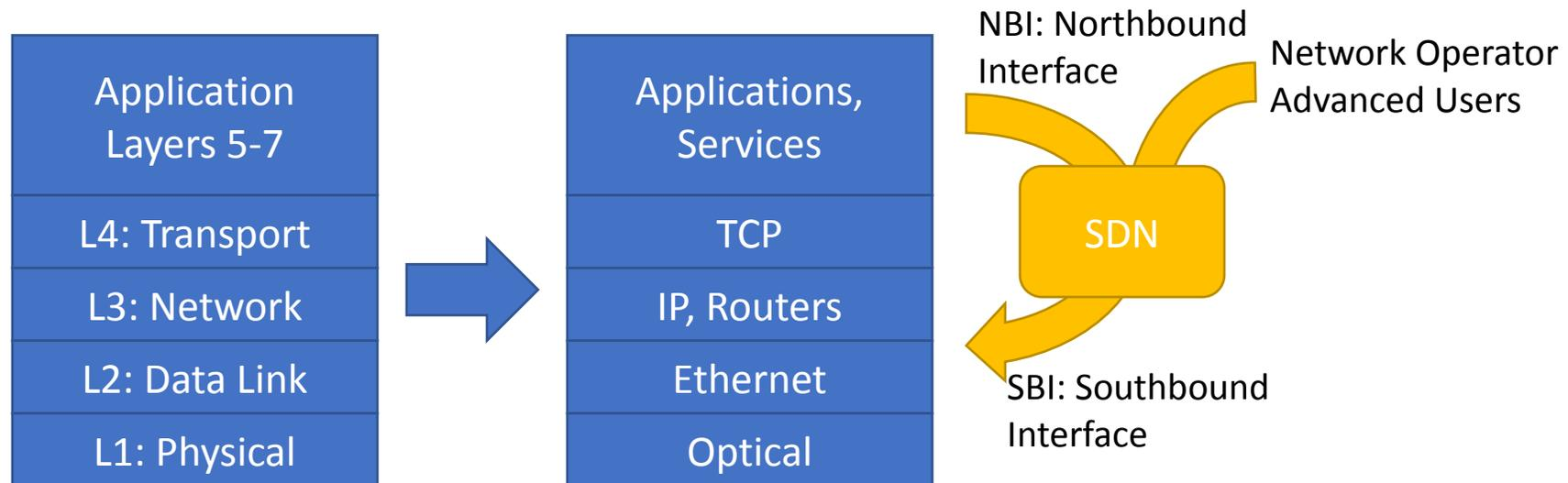

Quantum systems and coexistence

Quantum signals

- Quantum Key Distribution (QKD) signals
- Discrete variables (DV) and continuous variables (CV)

DV-QKD:

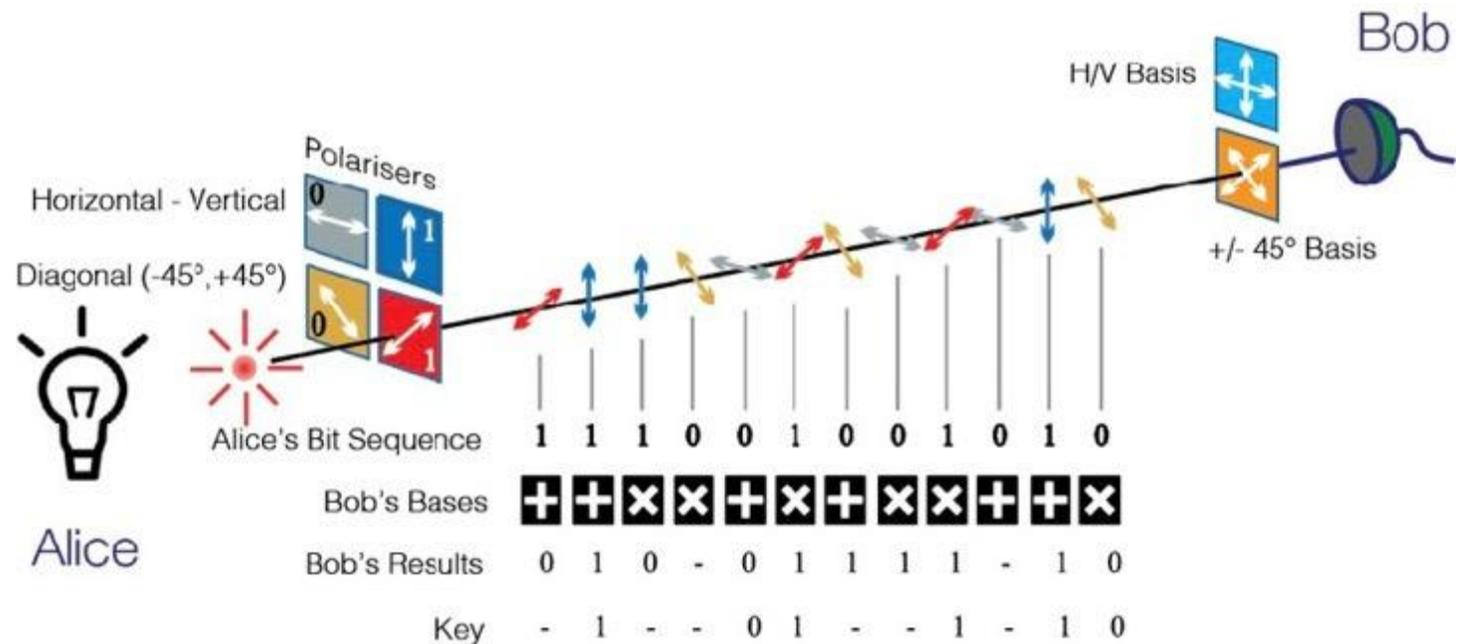

Iqbal et al., "Quantum Cryptography: A brief review of the recent developments and future perspectives", DIPEWC 2016

Continuous Variable Systems

- Use phase encoding of attenuated laser pulses
- Propagate LO with the weak signal (few photon)
 - Homodyne detection
- MDI/TF: Use intermediate 'Charlie' measurement node

CV-QKD:

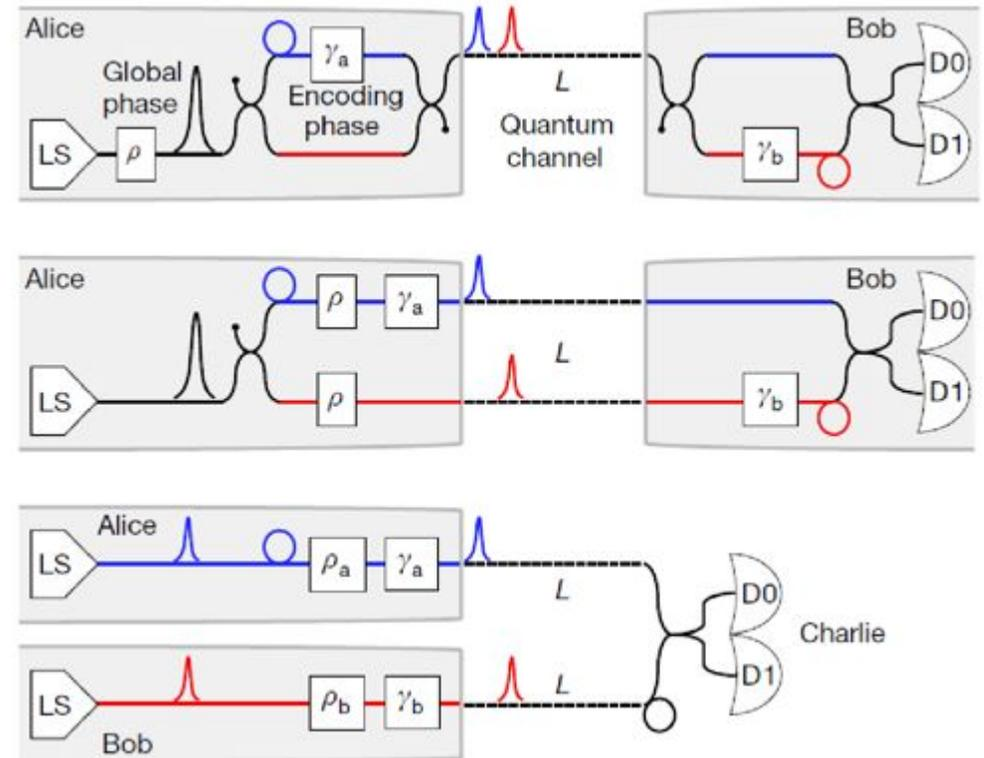

Quantum signals: Entanglement Distribution

- Entanglement is a resource that can be ‘distributed’
 - Use to perform quantum teleportation
 - Use for QKD protocols
- Photons can be used to distribute entanglement
 - Single rail:
 - Qubit memory (e.g. atom) is entangle with a presence of a photon
 - Dual rail:
 - Qubit is encoded on photon (e.g. H and V polarizations)
- Multipartite entanglement
- Quantum discord

Coexistence of classical and quantum signals

- Linear crosstalk
 - WSS, DWDM filters generally 30-40 dB isolation
 - Not enough for most quantum signals
- WDM (metro & long haul)
 - Uni-directional fibre, full duplex
 - Need to bypass amplifiers
- PON, PtP access
 - Bi-directional fibre
 - No-amplifiers

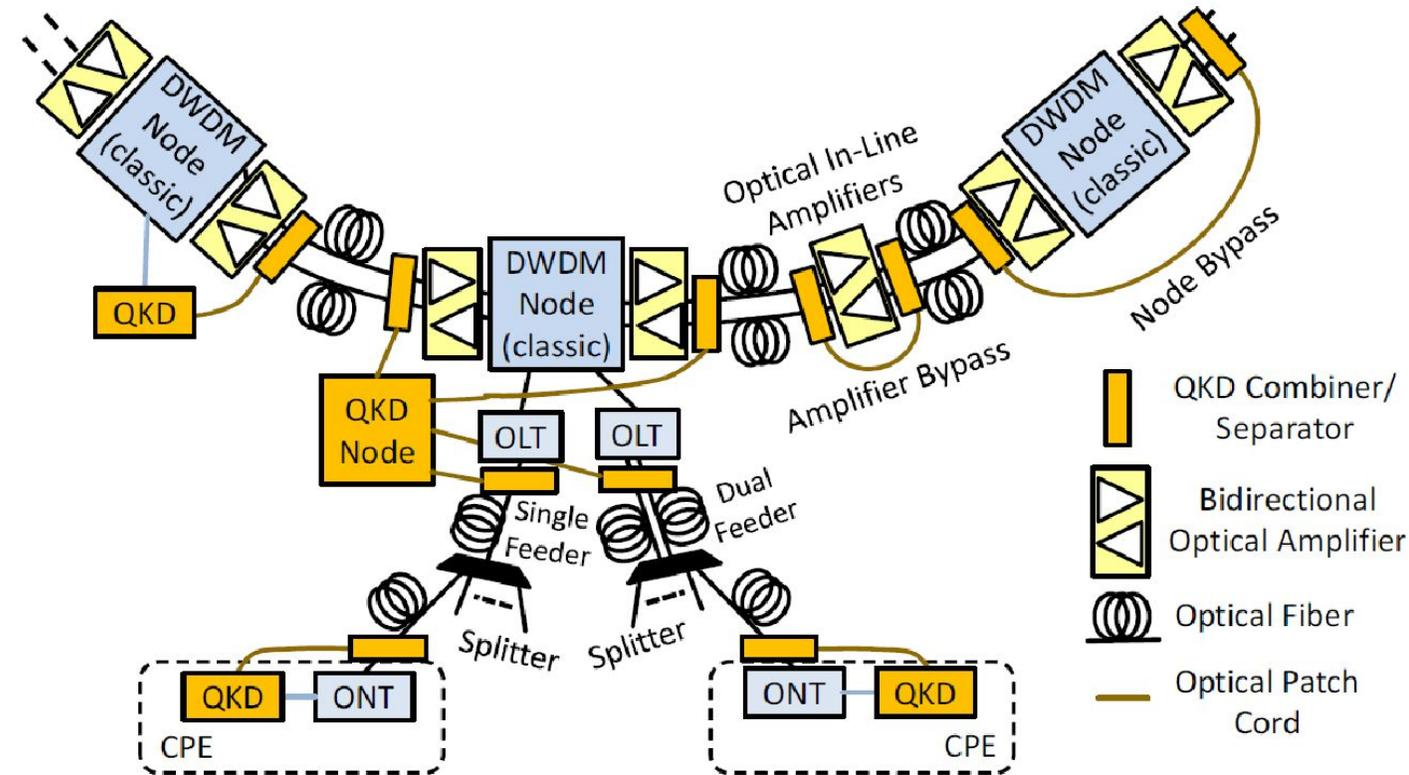

S. Aleksic, et. al. Opt Express 2015

Bi-directional Transmission (PON & PtoP)

- Backscattering is continuous

PON w/ 1550 nm downstream & 1310 nm upstream:

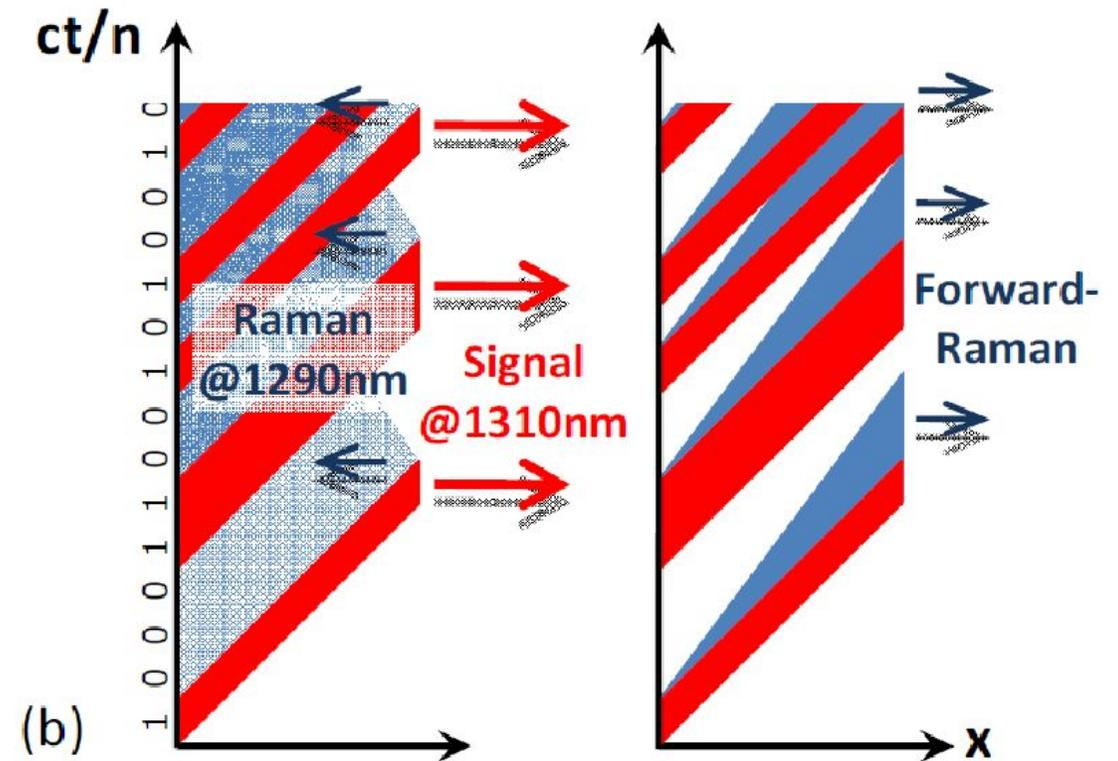
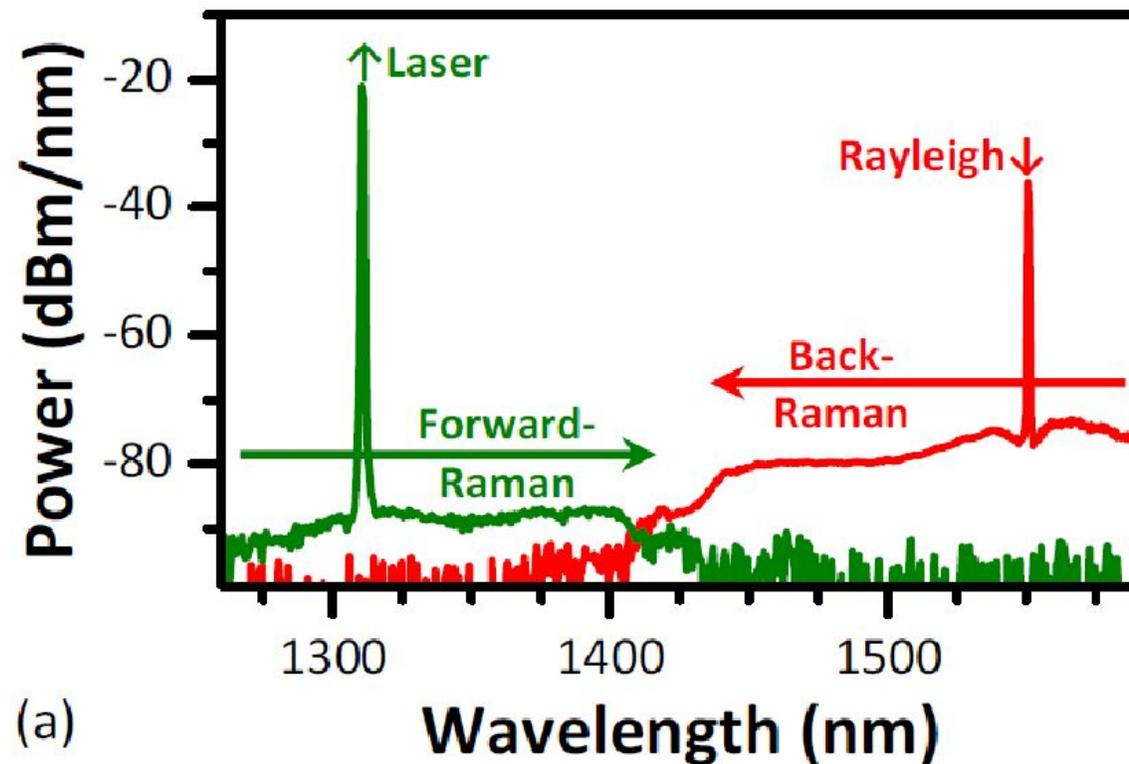

Raman Scattering

- Raman Scattering (Forward & Backward)
 - Also Rayleigh backscattering
 - Broadband (need to account for measurement BW)

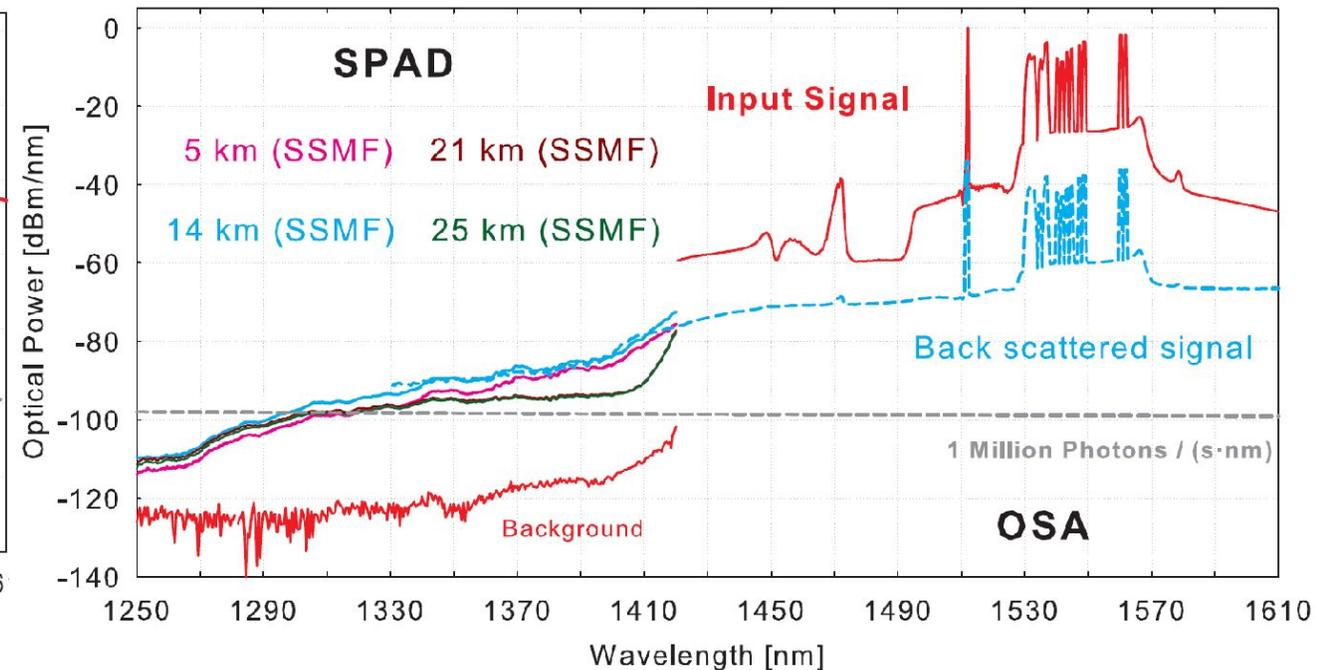
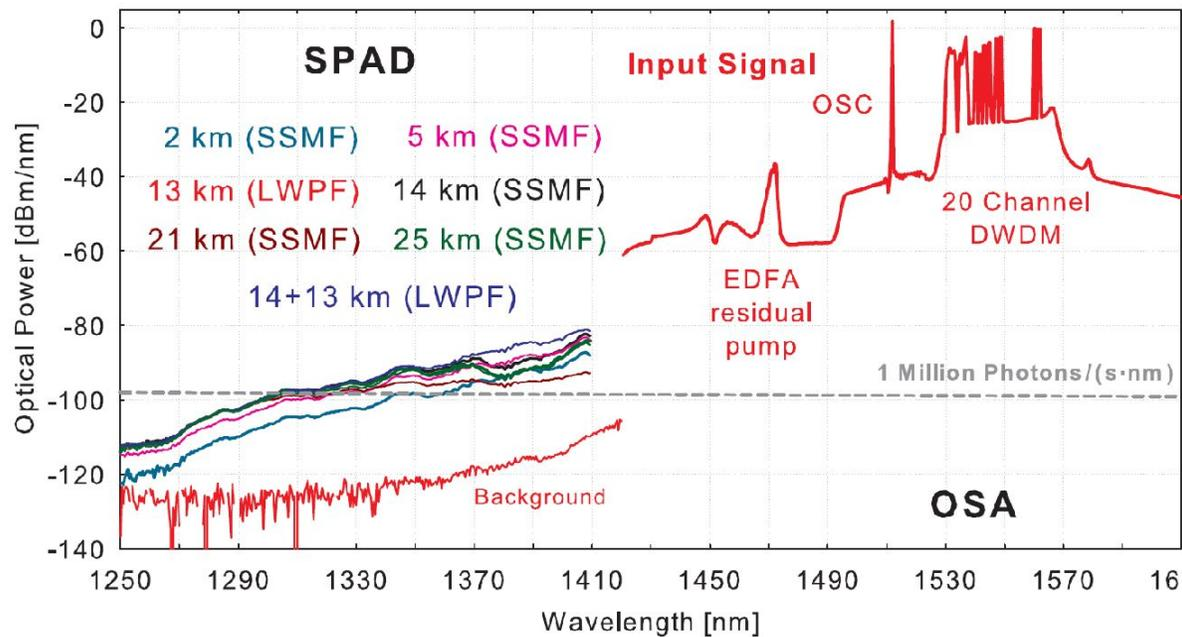

Coexistence Strategies

- Separate fibers/cores
 - Multi-core fiber
- Hollow core fiber
- Time-slotted transmission

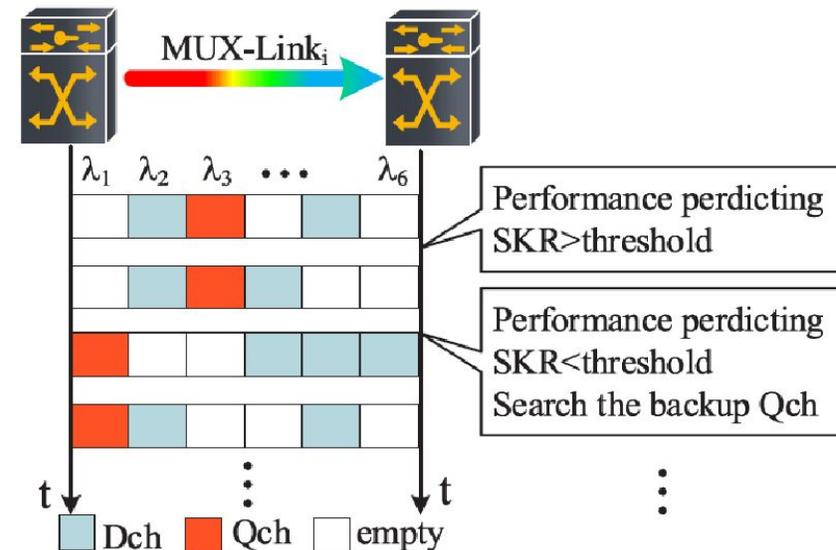
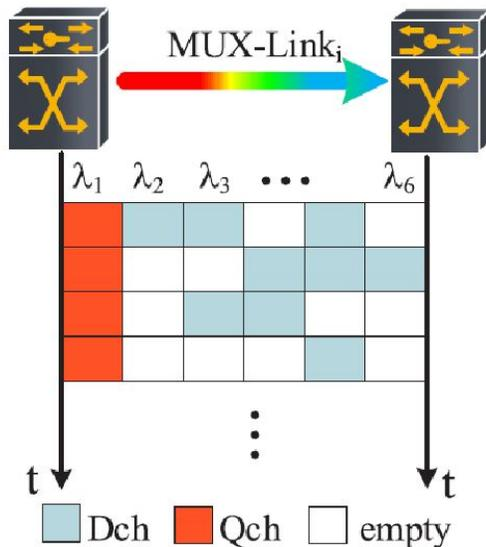

Entanglement distribution

- Single hop link, QM's are essentially small quantum computers
- Need to maintain equal propagation times to interfere photons at Heralding node
 - Can place Heralding measurement at one of the two end nodes
- What are potential challenges for this scheme?
 - Loss, polarization, timing jitter, synchronization, delay,...

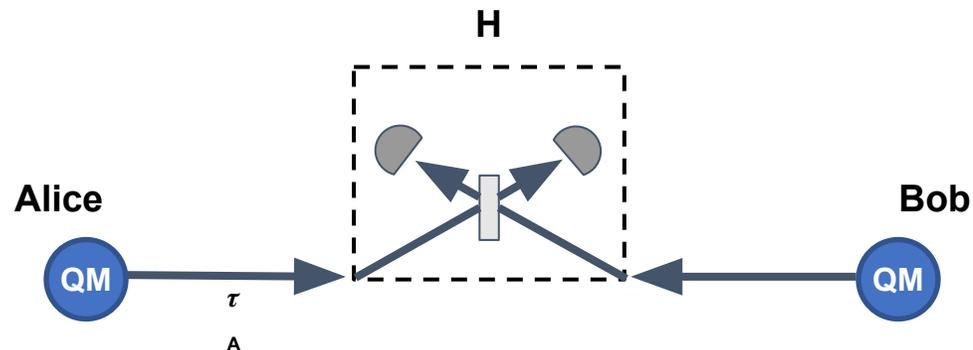

Identifying layers in quantum networks

- Network layers
 - Still open question how to define layers
 - Layers can typically be engineered and operated independently
 - Hard to identify independent quantum layers

Application	
Transport	Qubit transmission
Network	Long distance entanglement
Link	Robust entanglement generation
Physical	Attempt entanglement generation

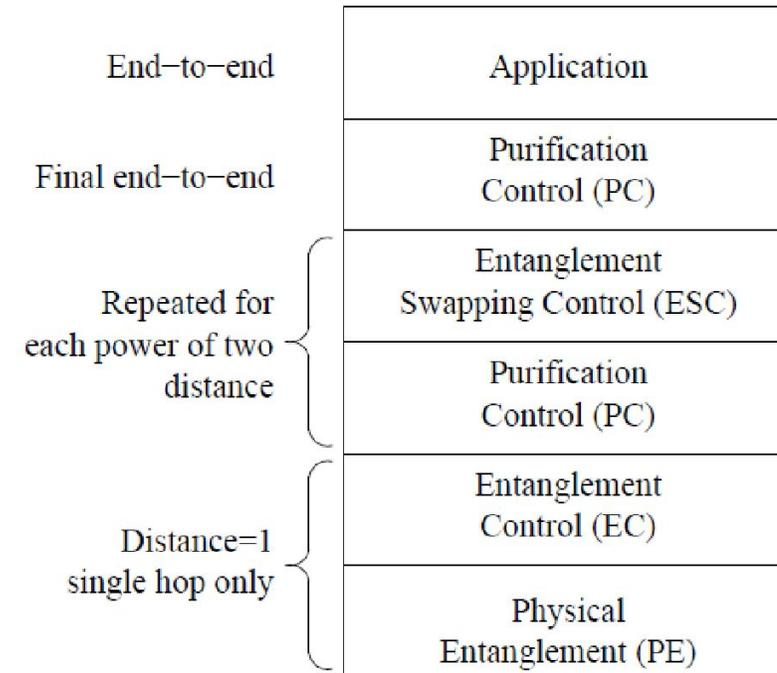

Van Meter, et. al. ARXIV 0705.4128v2

Dahlberg, et. al. ARXIV 1903.09778v1

Layer-independent methods

Software defined networking (SDN)

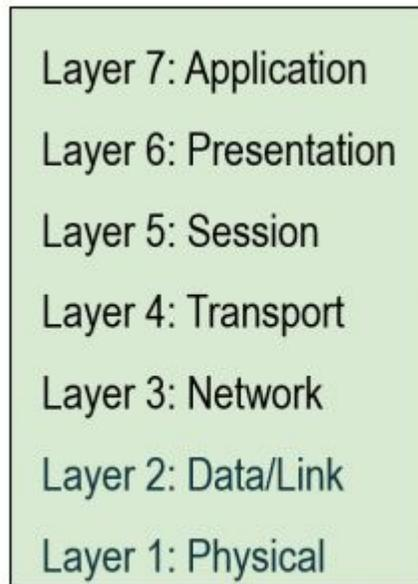
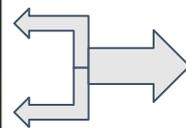

Figure 1: Networking layers



General quantum switching scheme studied through simulations

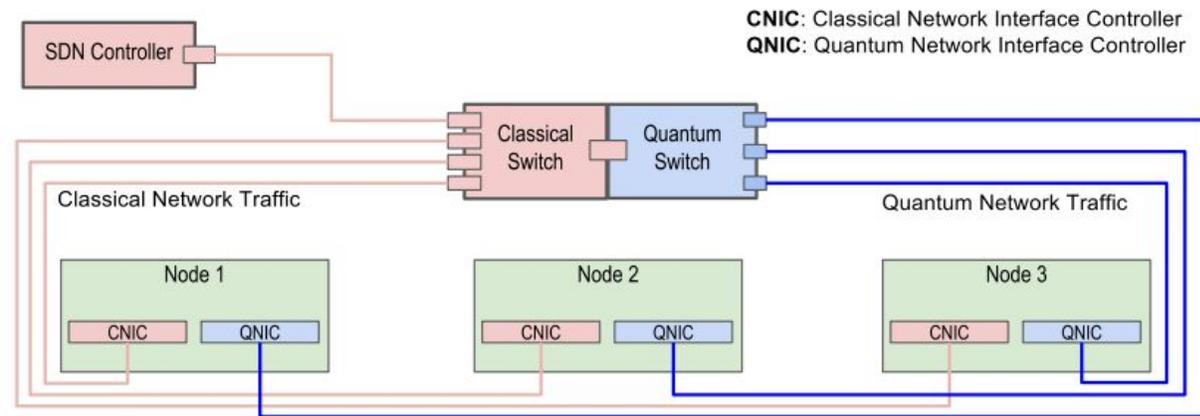
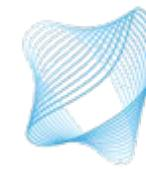
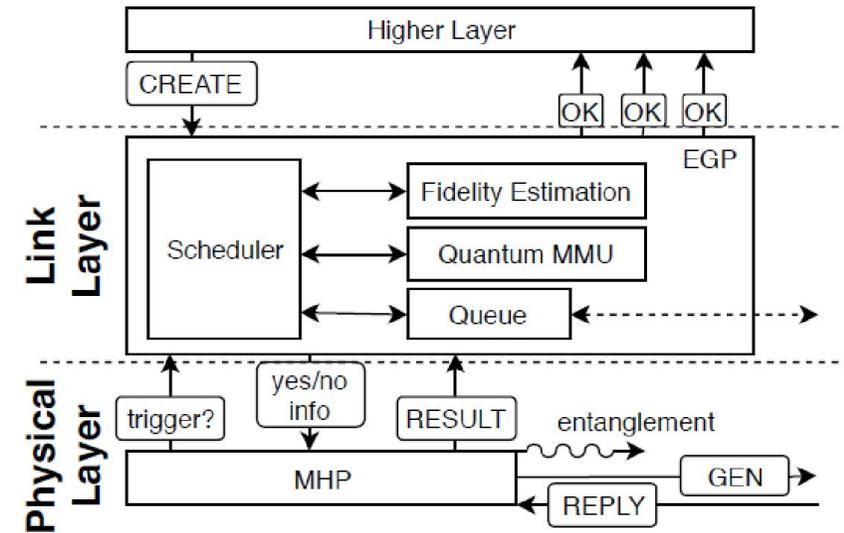

Figure 2: A schematic of a 3-node network including switch and network controller.

CV Quantum Repeater Protocol



- ‘Link Layer’ manages and schedules creation of ebits
- ‘Physical Layer’ establishes entanglement
- Requires coordination between layers
 - More of a cross-layer, SDN approach



Dahlberg, et. al. ARXIV 1903.09778v1

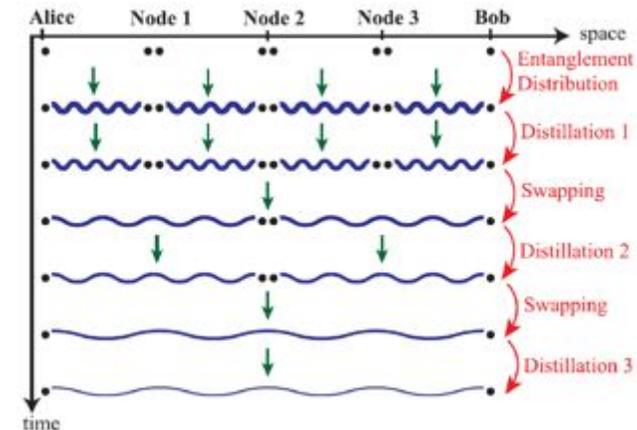

Field trials and test bed experiments

MONET Project 1996

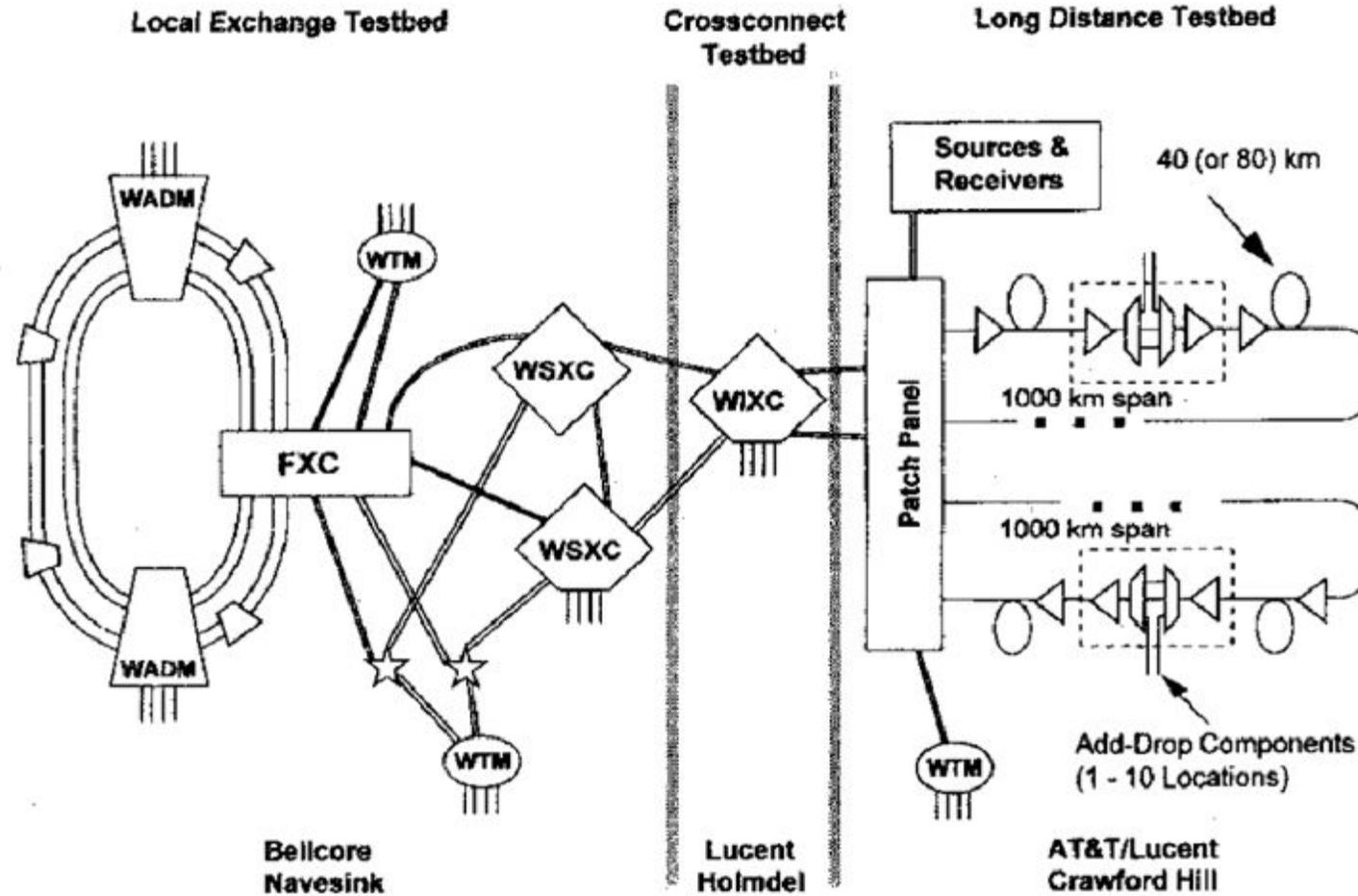
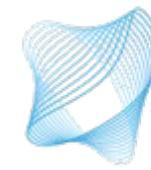
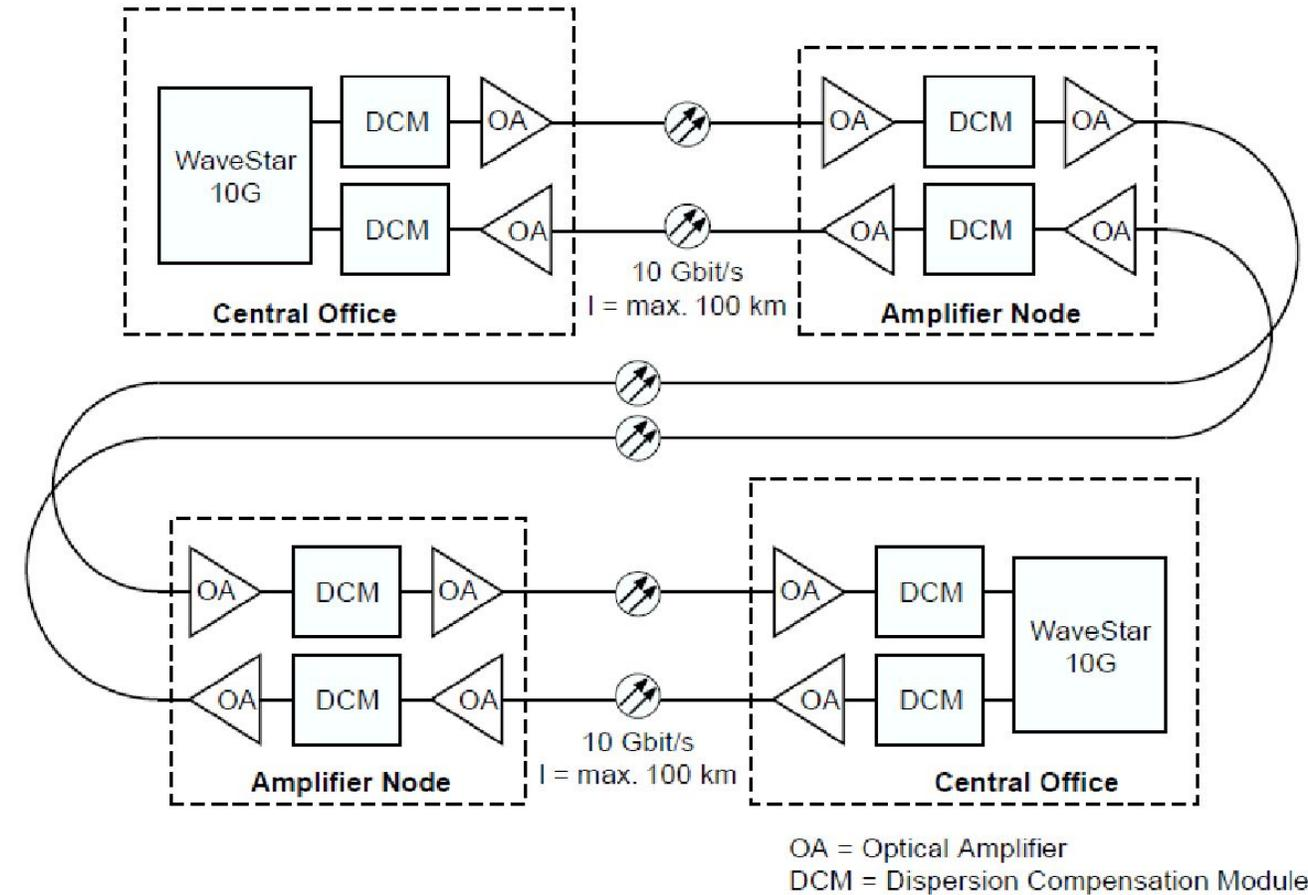

Fig. 4. The MONET New Jersey network.

What they built

- Point to point systems
- <6 fiber spans
- Each system manually designed and tuned for deployment



Technologies that got dropped

- Acousto-optic Tunable Filters
- Coherent transceivers (to return 20 years later)
- Wavelength cross-connects & ADMs (to return 10 years later)
- Tunable Transceivers (to return 10 years later)
- Mesh networks (to return 15 years later)
- SDM is becoming multiple parallel fibers

Metro Network Demonstration

- QKD integrated with classical network using SDN control
 - WDM CV-QKD along with classical signals (reduced power)
 - Used local QKD managers on each node
 - Showed multiple network functions:
 - Quantum secured data plane
 - Quantum secured control plane
 - Quantum secured network function virtualization



V. Martin et al., Center for Computational Simulation and ETSI Informáticos, Telefónica, Huawei, ICTON 2019

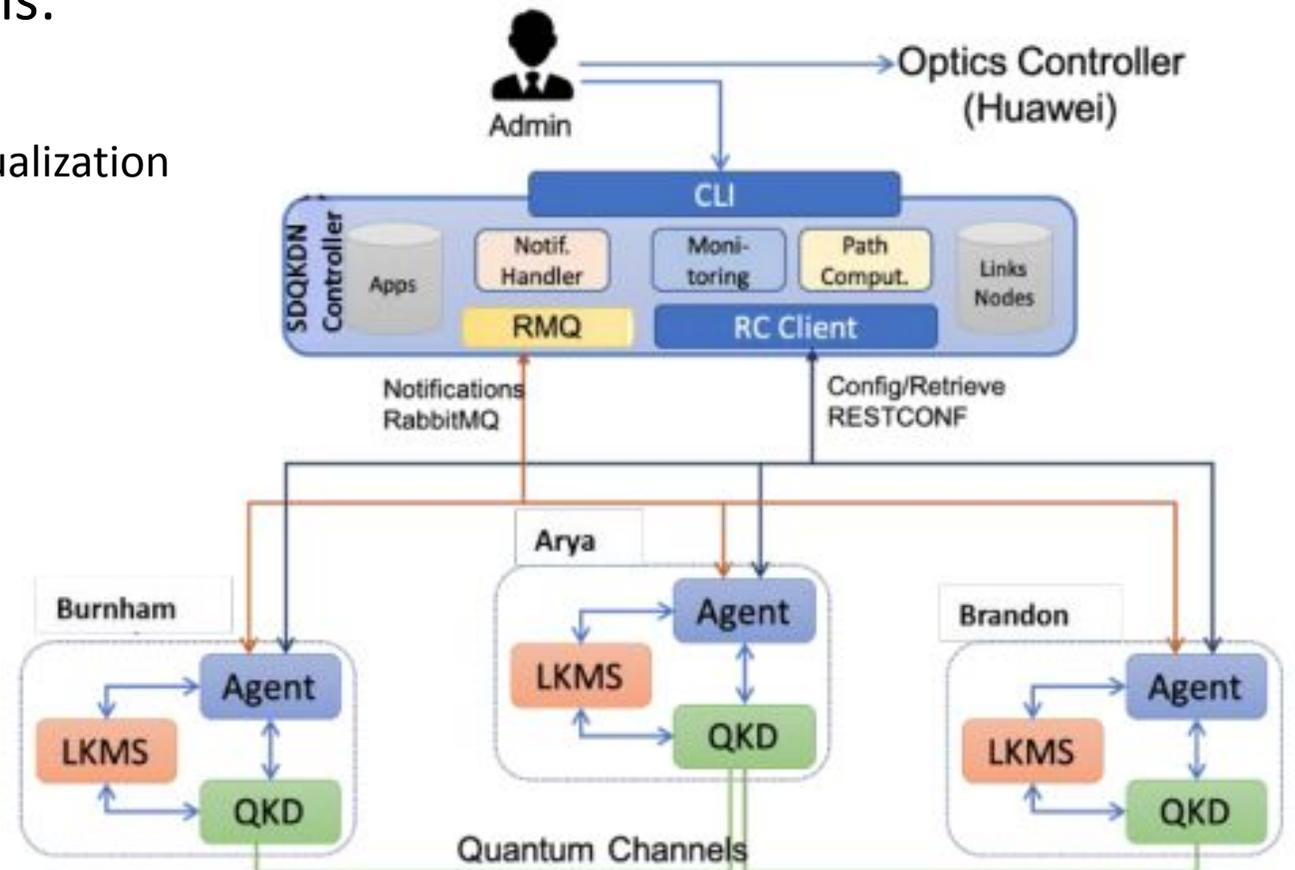

Bristol QKD SDN Experiments

Use SDN control functions to repond to different types of network attacks

- Monitor SKR and QBER
- Respond to optical scattering from attacker into quantum channel

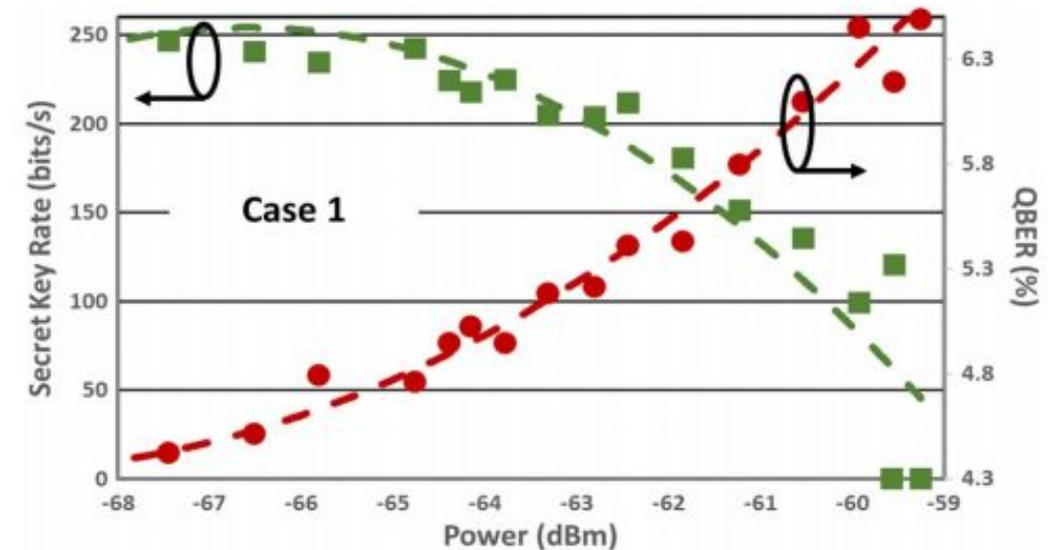
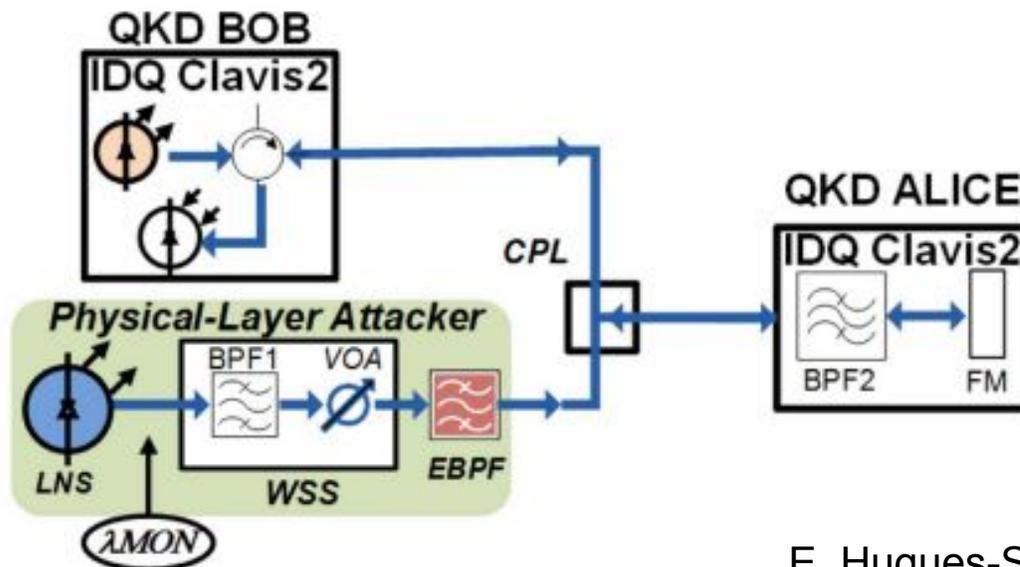

Hollow Core Fibre Experiments

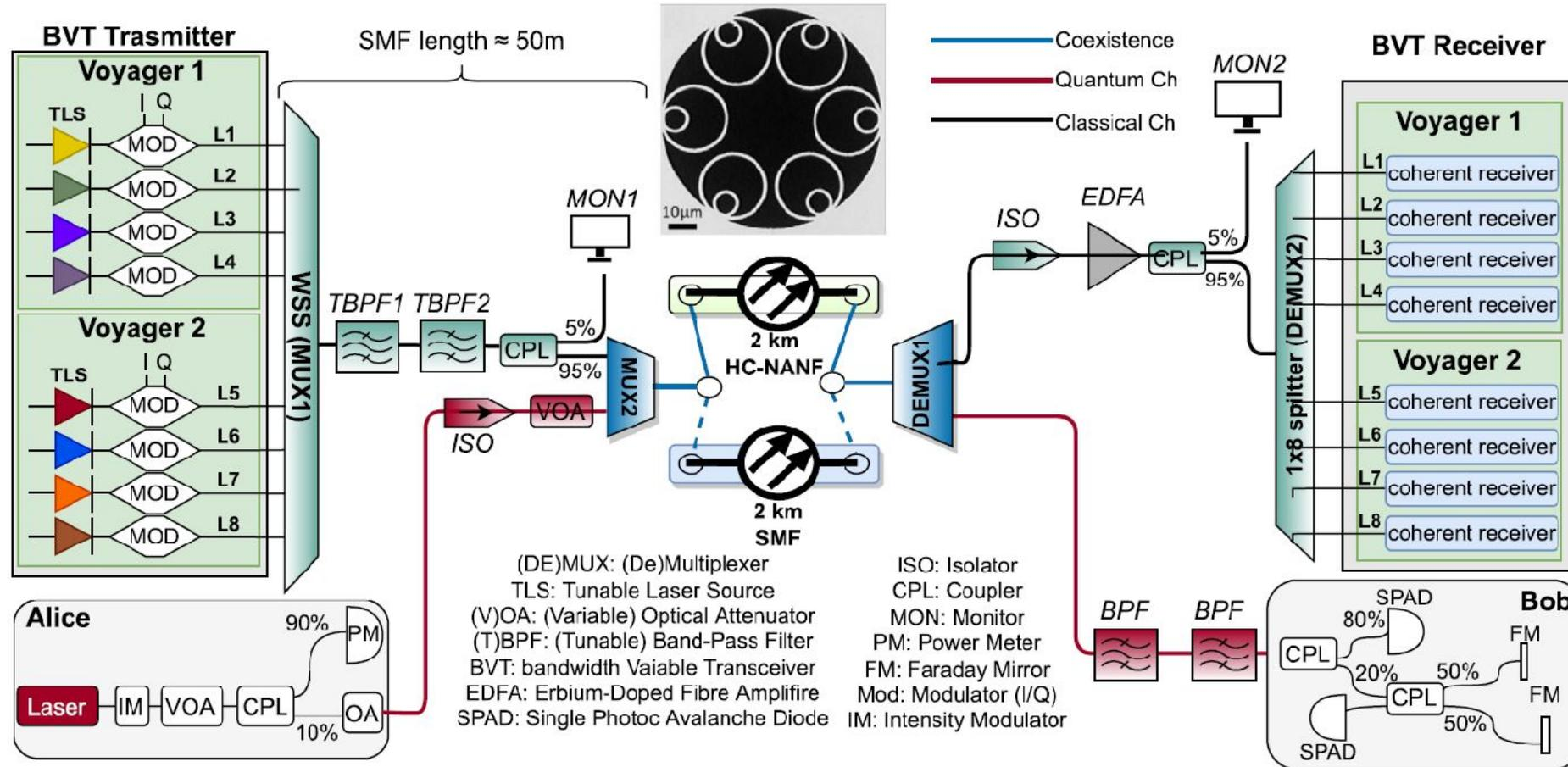

Multi-Core Fibre Experiments

Separate classical and quantum signals in different cores

- Linear crosstalk below 50 dB
- Use 10 Gb/s OOK signals at 0 dBm

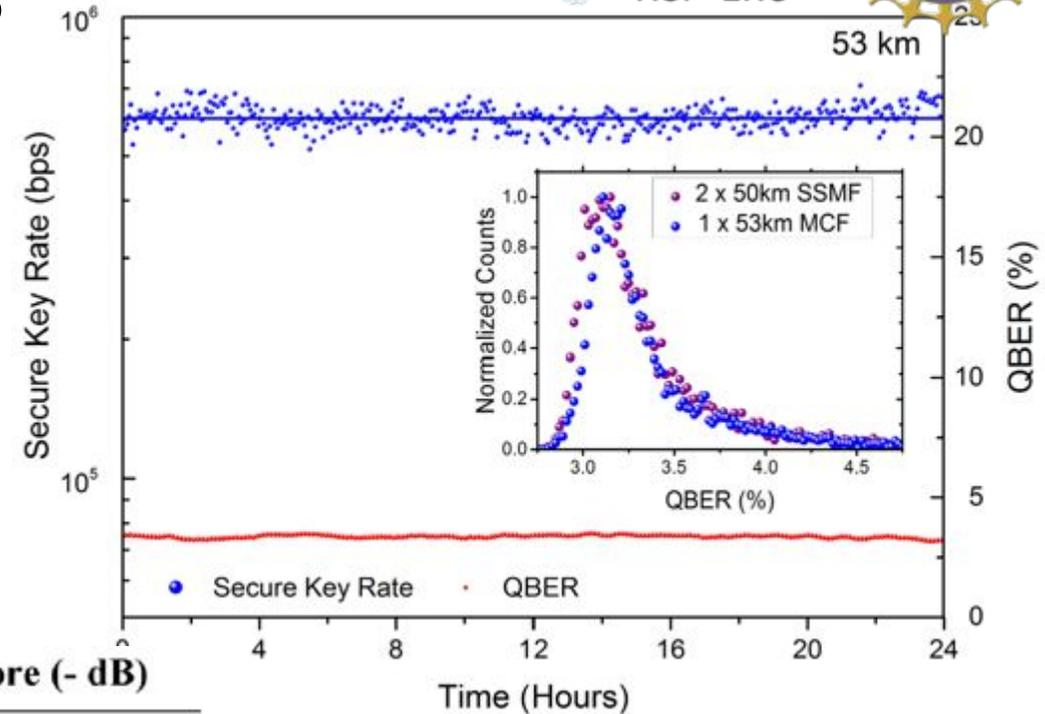

(a)

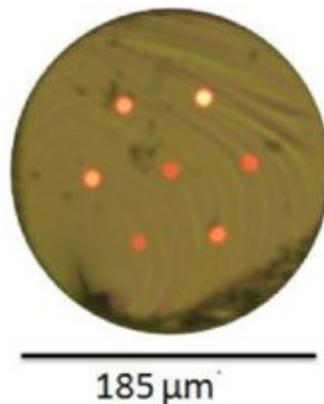

(b)

Core	Leakage into central core (- dB)	
	Forward	Backward
1	56.2	77.8
2	63.8	79.9
3	58.5	83.5

MDI-QKD Field Trial

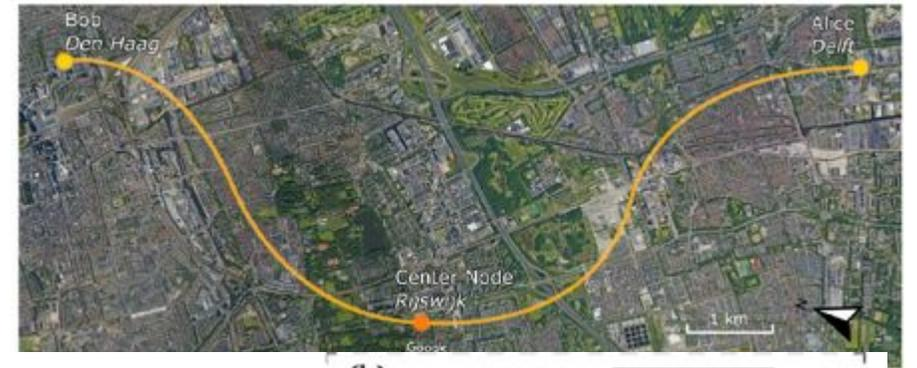

- Multiplexed with ROADM classical DWDM network
- 1310 nm QKD signals
- 1548 nm classical control channel
 - Clock distribution
- Frequency stabilized
- Polarization tracking

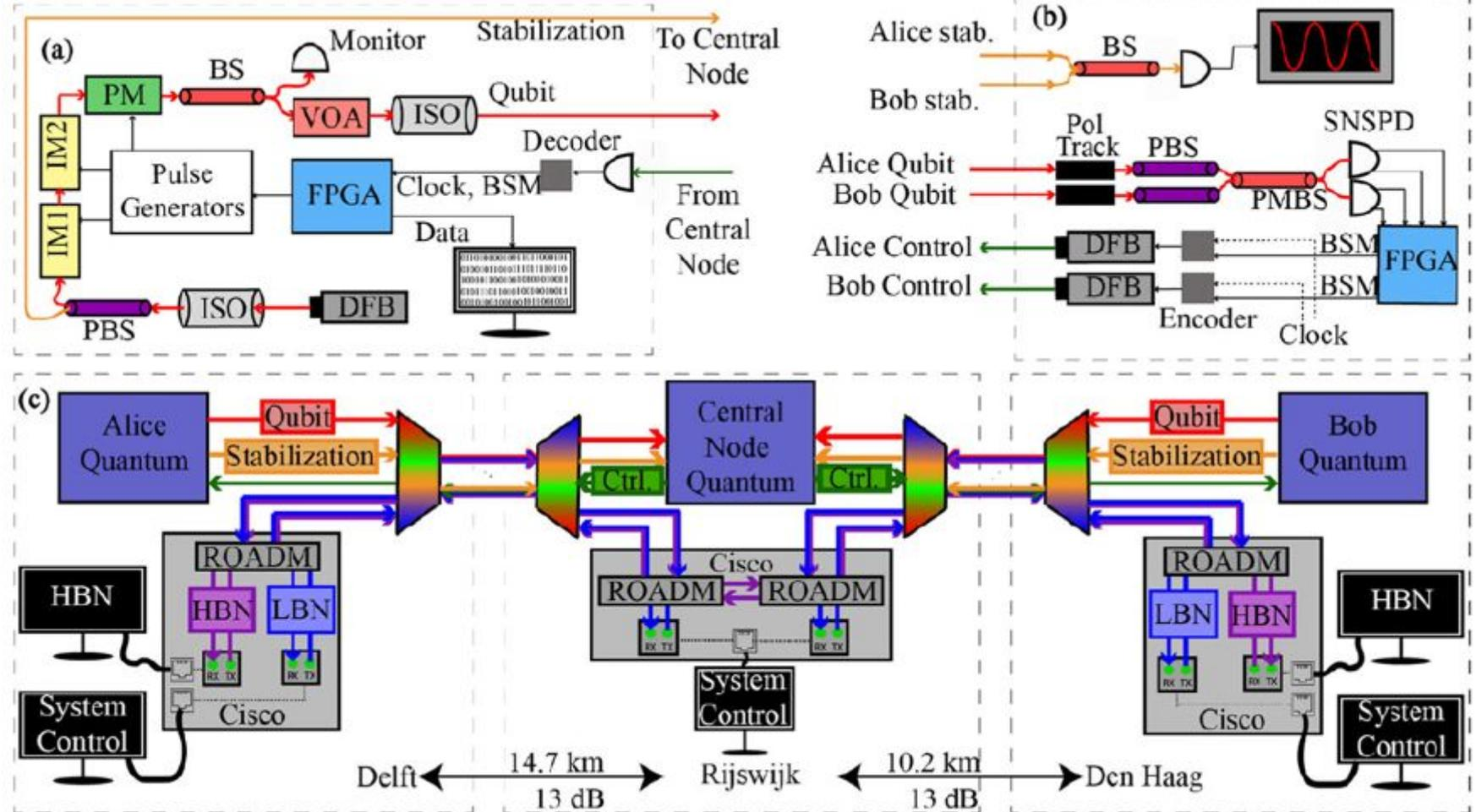

Further Reading

- Optical Fiber Telecommunications Vol. III-VI, Elsevier
 - Kaminow, Koch, Li, Willner, eds., chapters by leading experts on key topics spanning history of optical communications
- B. Mukherjee, I. Tomkos, M. Tornatore, P. Winzer, Y. Zhao, eds., Springer Handbook of Optical Networks, Springer 2020
- Papen, G. C. and Blahut R. E.: Lightwave Communications, Cambridge University Press 2019
- Cvijetic, M., Djordjevic. I. B.: Advanced Optical Communication Systems and Networks, Artech House 2012
- Agrawal, G.: Fiber-Optic Communication Systems, 4th Ed., Wiley 2010

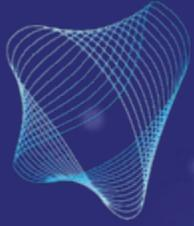

Center for
Quantum Networks
NSF Engineering Research Center

Course Evaluation Survey

We value your feedback on all aspects of this short course. Please go to the link provided in the Zoom Chat or in the email you will soon receive to give your opinions of what worked and what could be improved.

CQN Winter School on Quantum Networks

Funded by National Science Foundation Grant #1941583

